

# HSF

NOTES:  
 Current Rating:0.5AMP  
 Contact Resistance:30mΩ max  
 Withstand Voltage:100V AC/DC  
 Insulation Resistance:500MΩ min  
 Operation Temperature:-40℃ to +125℃

Contact Material:Phosphor Bronze  
 Cap Material:SUS,t=0.25mm  
 Housing Material:LCP(UL94V-0),Nature  
 Contact plating:Au and Tin over Ni

Flatness: <80Pins The "M" Is 0.12mm MAX  
 ≥80Pins The "M" Is 0.15mm MAX

Recommended P. C. B Layout (Top Side)  
 (PCB BOARD TOLERANCE ±0.05)

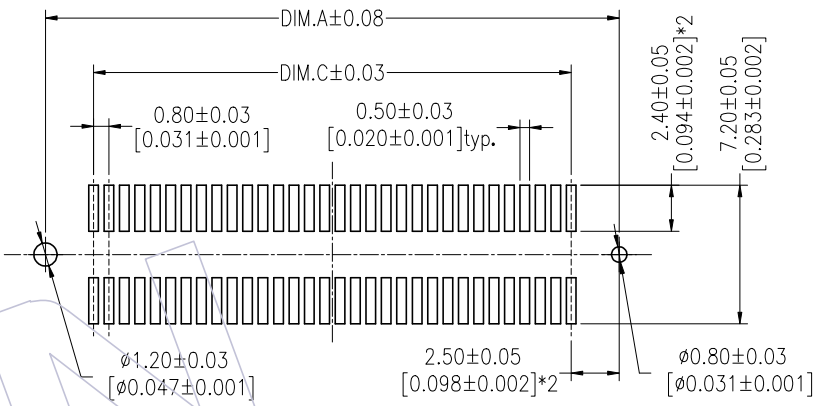
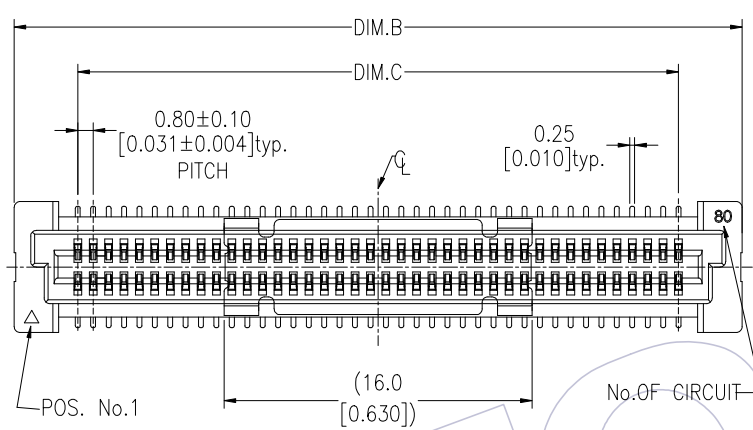

## Ordering Information

3616-S XXX -077 XX R 01

No.of Pins Housing High Contact Plating R=Tape&Reel+CAP  
 S1=3u"Gold/Tin  
 S3=10u"Gold/Tin

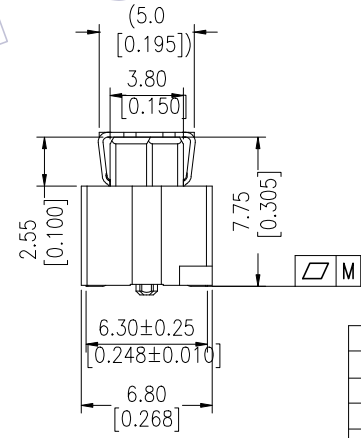
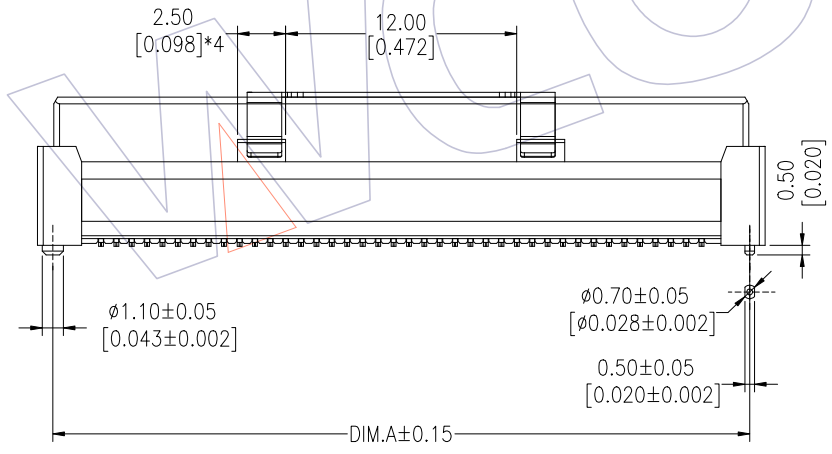

79.20	85.80	84.20	200
71.20	77.80	76.20	180
63.20	69.80	68.20	160
55.20	61.80	60.20	140
47.20	53.80	52.20	120
39.20	45.80	44.20	100
31.20	37.80	36.20	80
23.20	29.80	28.20	60
15.20	21.80	20.20	40
DIM.C	DIM.B	DIM.A	PIN NO.

REV	DATE	MODIFICATION DESCRIPTION	CHANGE	OPERATION		DRAW	DATE	SCALE	FIT	PART NO.
				DIM	TOL					
				X.X	±0.40	Allen	2014/11/07	UNIT	mm	3616-SXXX-077XXR01
A1	2014/11/07	Modify	△	X.XX	±0.25	CHECK	DATE	SIZE	inch	
A0	2014/06/24	NEW	—	X.XXX	±0.15	APPROVE	DATE	SHEET	1/2	
				Angle	± 3'			PROJ.	φ	Customer NO.

**WCON**  
 Http: www.wcon.com

WCON-Dongguan Tel: +86 769 85358920 Fax: +86 769 85358915 E-mail: sales@wcon.com

WCON-Kunshan Tel: +86 512 57468408 Fax: +86 512 57468468 E-mail: salesks@wcon.com

HSF

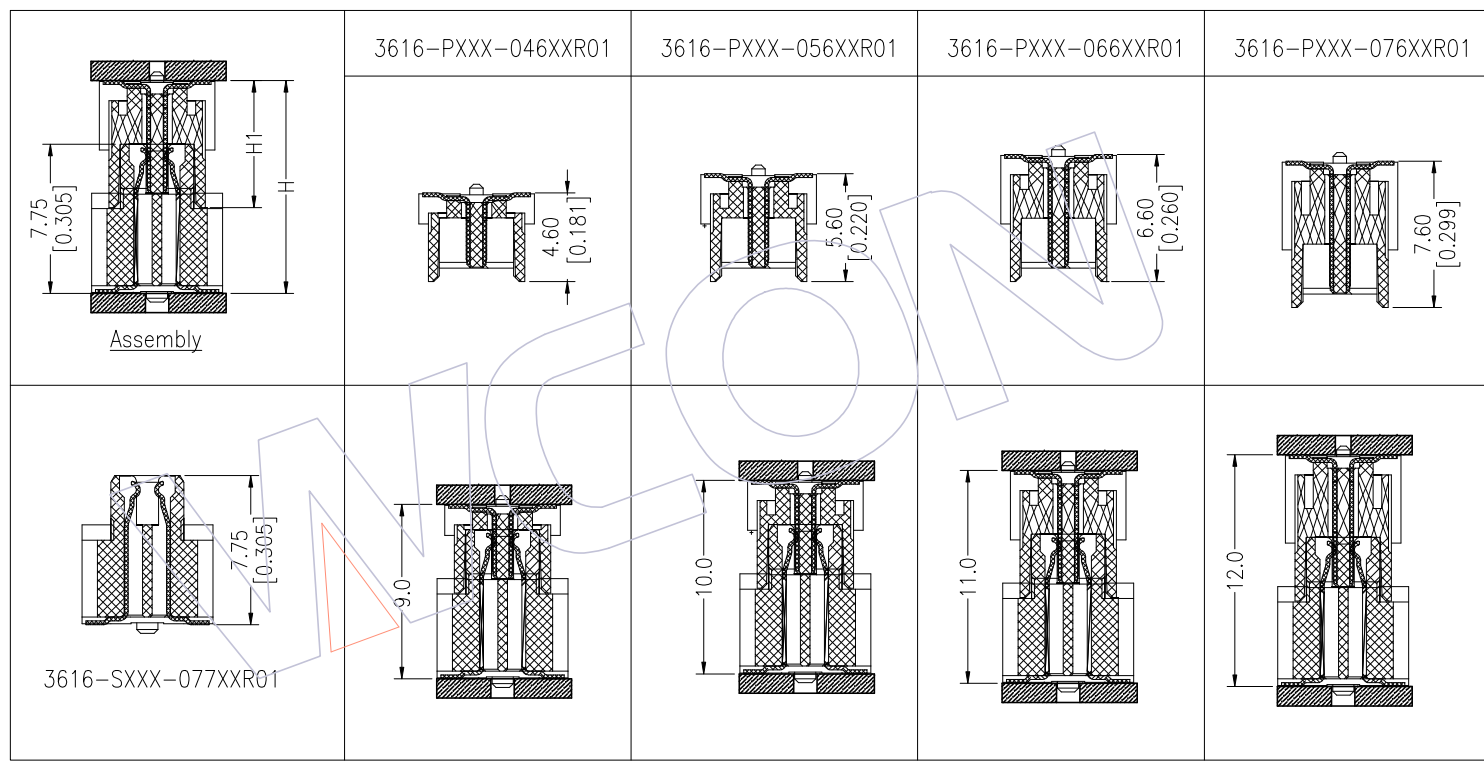

REV	DATE	MODIFICATION DESCRIPTION	CHANGE	OPERATION		DRAW	DATE	SCALE	FIT	PART NO.
				X.X	±0.40					
A1	2014/11/07	Modify		X.XX	±0.25	Allen	2014/11/07	UNIT	mm	3616-SXXX-077XXR01
A0	2014/06/24	NEW		X.XXX	±0.15	CHECK	DATE	inch	A4	
				Angle	± 3'	APPROVE	DATE	SHEET	2/2	TITLE: 0.80mm B TO B Female H=7.75 "T" TYPE SMT
				DIM	TOL			PROJ.		Customer NO.

**WCON**  
Http: www.wcon.com

WCON-Dongguan Tel: +86 769 85358920  
WCON-Kunshan Tel: +86 512 57468408  
Fax: +86 769 85358915 Fax: +86 512 57468468  
E-mail: sales@wcon.com E-mail: salesks@wcon.com