

HSF

NOTES:
 Rated Current:1.0AMP.
 Contact Resistance:20mΩ Max.
 Withstand Voltage:500V AC/DC
 Insulation Resistance:1000MΩ Min.
 Operation Temperature:-40°C to +105°C

Contact Material:Brass
 Contact Plating:Au or Sn Over Ni
 Insulator Material:PA9T+33%G.F UL94V-0 BK

Recommended P.C.B Layout (Top Side)
 (PCB BOARD TOLERANCE±0.05)

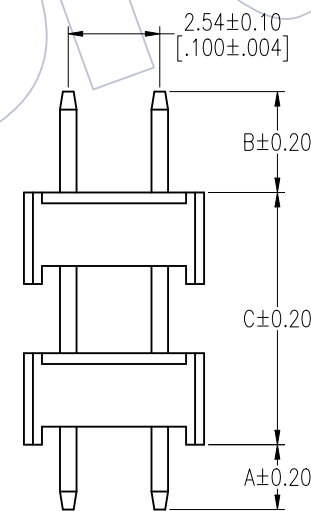
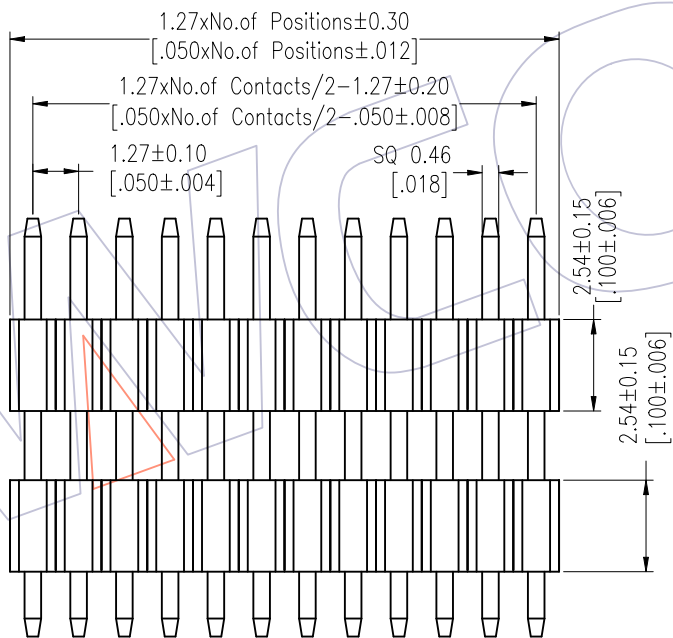
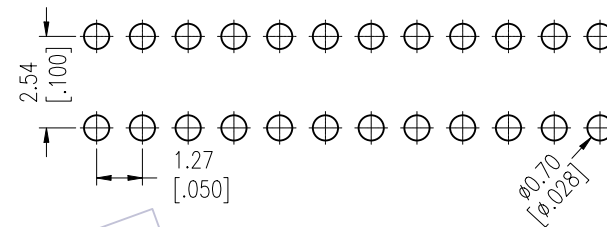
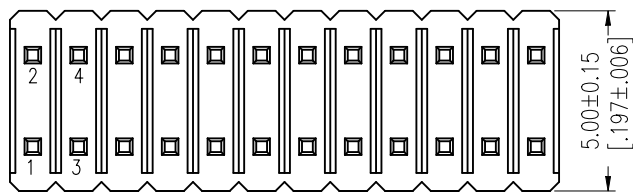

Ordering Information

1425-22 XX XX S XXX C A XX

| No. of Pins | Contact Plating | Pin Length | Insulator | Packing | Series No. |
|---------------|--|------------|-----------|---------|------------|
| Per Row:02~50 | G0=Gold Flash G3=10u"Gold G4=15u"Gold G5=30u"Gold | L=A+B+C | C=PA9T | A=Tray | 01~99 |
| | S0=Gold Flash/Tin S3=10u"Gold/Tin S4=15u"Gold/Tin S5=30u"Gold/Tin | | | | |
| | SN=Tin SM=Matte Tin | | | | |

| Item | Pin Length | A | B | C | Mating |
|-----------|------------|------|------|----|--------|
| Standard | -- | 1.80 | 2.80 | -- | 2446 |
| | -- | 1.80 | 6.00 | -- | 2485 |
| Alternate | | | | | |

| OPERATION | DRAW | DATE | SCALE | Fit | PART NO. |
|-------------|--------------|------------|-------|-----------|--|
| x.x ±0.40 | William Chen | 2018/01/12 | UNIT | mm [inch] | 1425-22XXXXSXXXCXXX |
| x.xx ±0.25 | CHECK | DATE | SIZE | A4 | TITLE: 1.27*2.54 Pin Header, DUAL ROW, S/T, DOUBLE PLASTIC, H=2.54 |
| x.xxx ±0.15 | APPROVE | DATE | SHEET | 1/1 | Customer NO. |
| Angle ± 3' | | | PROJ. | | |
| DIM TOL | | | | | |

WCON
 Http: www.wcon.com
 WCON-Dongguan Tel: +86 769 85358920
 WCON-Kunshan Tel: +86 512 57468408
 Fax: +86 769 85358915
 Fax: +86 512 57468468
 E-mail: sales@wcon.com
 E-mail: salesks@wcon.com

| REV | DATE | MODIFICATION DESCRIPTION | CHANGE |
|-----|------------|--------------------------|--------|
| A1 | 2018/01/12 | MODIFY PART NO. | ----- |
| A0 | 2012/04/06 | NEW | ----- |