

# HSF

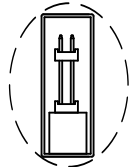

3123-XXSXXBD00TX

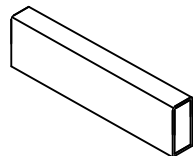

No: 1

产品装入真空管内  
SG-A21 (600mm方型真空管)

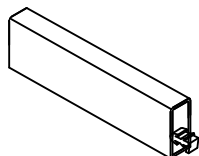

No: 2

塞塑胶塞



PE-31(185\*750mm)

PE袋

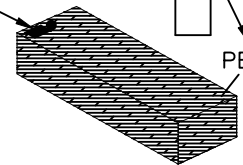

No: 3

20管为一扎套PE-31袋中, 内附1包干燥剂  
封口机封口, 封箱胶缠绕PE袋两端  
再贴标签

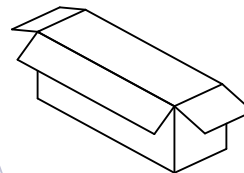

No: 4

真空管装入内箱(4扎/内箱)  
内箱规格: CTN-10A(双坑A=B 63\*15\*15CM)

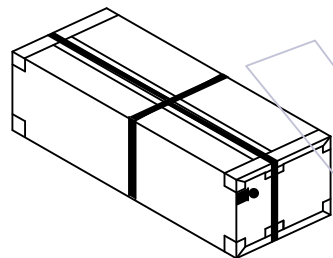

No: 8

打包装带

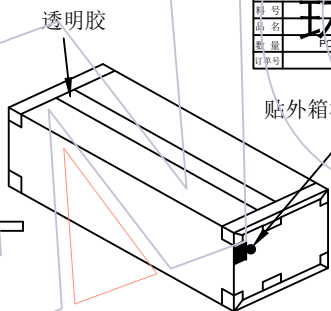

No: 7

封箱及贴标签于外箱侧面的左上角

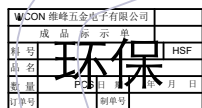

贴外箱标签及ROHS标签

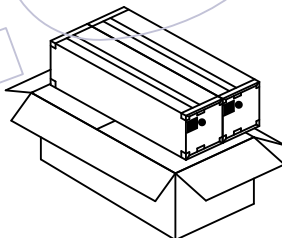

No: 6

内箱放入外箱(2内箱/外箱)  
外箱规格: CTN-10C(双坑A=A 65\*33\*17CM)

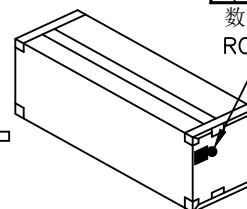

No: 5

封箱及贴标签于内箱侧面的左上角  
(80管/内箱)



数量标签及  
ROHS标签

2.0筒牛, 180度, 加二层排针塑胶						
规格	真空管 装数量	每内箱 装数量	每外箱 装数量	规格	真空管 装数量	每内箱 装数量
6P	67	5360	10720	26P	20	1600
8P	54	4320	8640	28P	18	1440
10P	46	3680	7360	30P	17	1360
12P	39	3120	6240	32P	16	1280
14P	34	2720	5440	34P	15	1200
16P	31	2480	4960	40P	13	1040
18P	28	2240	4480	44P	12	960
20P	25	2000	4000	50P	11	880
22P	23	1840	3680	60P	9	720
24P	21	1680	3360	64P	8	640

## 说明:

1. 产品如图所示型态放入真空管
2. 注意各标签样式, 位置及方向的一致性;
3. 打外箱包装带时需注意, 打为十字型.

变更记事

版次 REV	日期 DATE	变更说明 MODIFICATION DESCRIPTION	变更 CHANGE	核准 APPROVE
A0	10/08/03	NEW		

零件图		颜色 COLOR	材质 MATERIAL	设计 DESING	审核 CHECK	核准 核 准
X.				马云青	10/08/03	
X.X	±0.20					
X.XX	±0.10					
X.XXX	±0.05					
Angle						
X.	± 2'					
DIM	TOL					

SCALE	1:1
UNIT	mm
SIZE	A4
SHEET	1/1
PROJ.	☐

# WCON

WCON Electronics (GUANGDONG) Co., Ltd

料号 PART NO. 3123-XXSXXBD00TX

品名 TITLE: 2.0筒牛, 180度, 加二层排针塑胶, 包装规范