

HSF

NOTES:

Rated Current:1.5AMP.(20°C,2*2P-2*15P)
 1.0AMP.(20°C,2*16P-2*50P)

Contact Resistance:20mΩ Max.

Withstand Voltage:500V AC/DC

Insulation Resistance:1000MΩ Min.

Operation Temperature:-40°C to +125°C(Gold Plating)

-40°C to +105°C(Tin Plating)

Contact Material:Copper Alloy

Contact Plating:Au or Sn Over 30u" Min Ni

Insulator Material:PA9T+G.F UL94V-0 BK

Ordering Information

1325-2 2 XX XX M XXX C R XX

Plastic Layer
 Plastic Row
 No.of Pins
 Per Row:02-50
 Contact Plating
 G0=Gold Flash
 G3=10u"Au, BG3=8u"PdNi+2u"Au
 G4=15u"Au, BG4=13u"PdNi+2u"Au
 G5=30u"Au, BG5=28u"PdNi+2u"Au
 S0=Gold Flash/Tin
 S3=10u"Au/Sn, P3=8u"PdNi+2u"Au/Sn
 S4=15u"Au/Sn, P4=13u"PdNi+2u"Au/Sn
 S5=30u"Au/Sn, P5=28u"PdNi+2u"Au/Sn
 SN=Bright Tin
 SM=Matte Tin

Series No.
 01-99
 Packing
 T=Tube
 P=Tube+CAP
 R=Tape&Reel+CAP
 Insulator Material
 C=PA9T(Standard)
 Pin Length
 L(See Table)
 Type:
 M=SMT

PIN(PerRow)	2-15P	16-30P	31-50P
M	0.10	0.12	0.15

REV	DATE	MODIFICATION DESCRIPTION	CHANGE	DIM	TOL	OPERATION	DRAW	DATE	SCALE	Fit	PART NO.
A4	2025/09/16	Standardization Drawing	CP			OPERATION	DRAW	2025/09/16	SCALE	Fit	1325-22XXXXMXXXCXXX
A3	2023/02/02	Add Flatness	Du Ying	x.X	±0.40	CHECK	CP	2025/09/16	UNIT	mm [inch]	TITLE:
A2	2021/12/28	MODIFY CAP	Du Ying	x.XX	±0.25	TANG	CHECK	2025/09/16	SIZE	A4	1.27 Pin Header, DUAL ROW, SMT, DOUBLE PLASTIC, WITHOUT POST, H=2.5
A0	2012/03/31	NEW	-----	x.XXX	±0.15	APPROVE	TANG	2025/09/16	SHEET	1/9	Customer NO.
				Angle	± 3'	Steven Zhao	APPROVE	2025/09/16	PROJ.		

Recommended P.C.B Layout (Top Side) (PCB BOARD TOLERANCE±0.05) (PCB Thickness:T=1.60m)

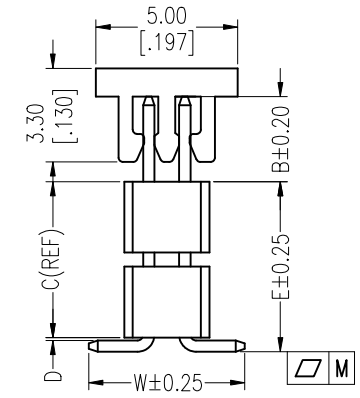
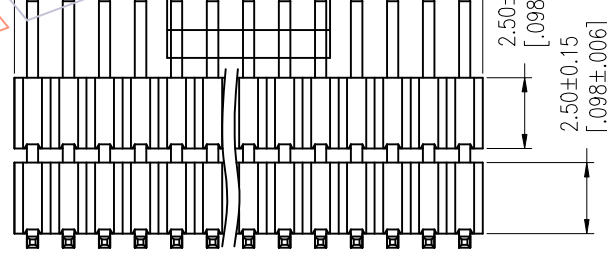
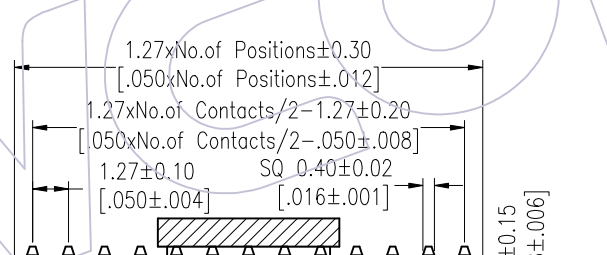
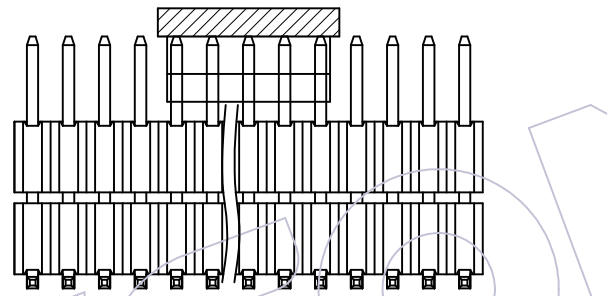
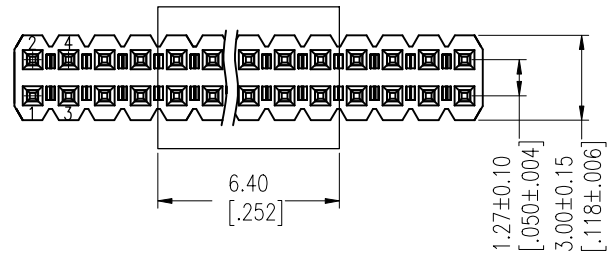
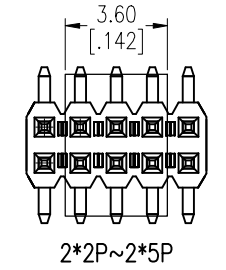
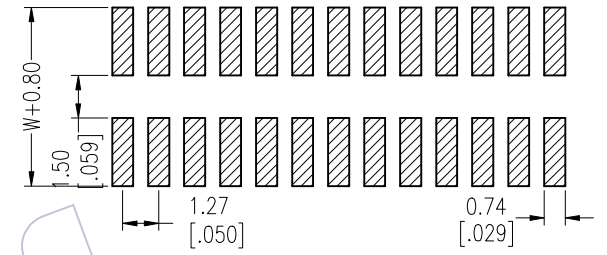

TYPE-2

TYPE-1

WCON
 Http: www.wcon.com

WCON-Dongguan
 Tel: +86 769 85358920
 Fax: +86 769 85358915
 E-mail: sales@wcon.com

WCON-Kunshan
 Tel: +86 512 57468408
 Fax: +86 512 57468468
 E-mail: sales@wcon.com

HSF

Packing:

Reel:

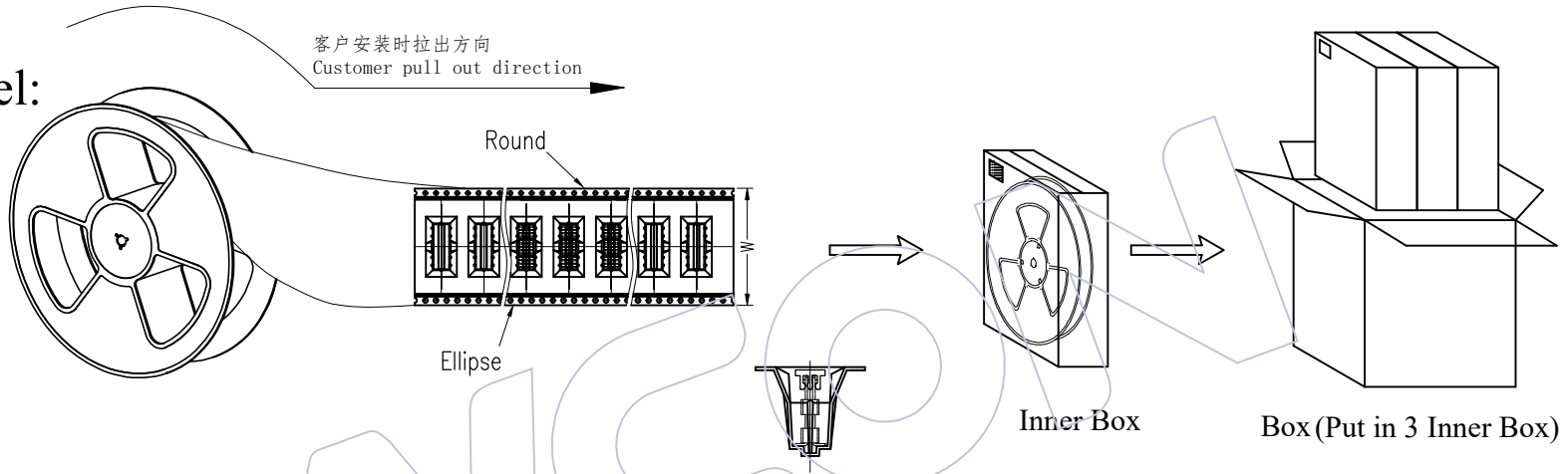

Tube:

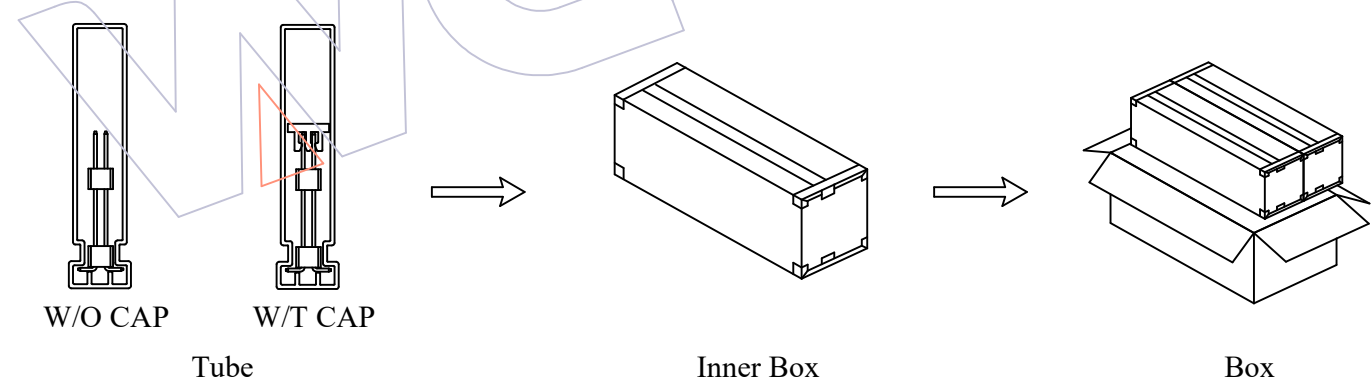

A4	2025/09/16	Standardization Drawing	CP	OPERATION	DRAW	DATE	SCALE	Fit	PART NO. 1325-22XXXXMXXXCXXX
A3	2023/02/02	Add Flatness	Du Ying	X.X ±0.40	CP	2025/09/16	UNIT	mm [inch]	
A2	2021/12/28	MODIFY CAP	Du Ying	X.XX ±0.25	CHECK	DATE	SIZE	A4	TITLE: 1.27 Pin Header, DUAL ROW, SMT, DOUBLE PLASTIC, WITHOUT POST, H=2.5
A0	2012/03/31	NEW	-----	X.XXX ±0.15	TANG	2025/09/16	SHEET	2/9	
REV	DATE	MODIFICATION DESCRIPTION	CHANGE	Angle ± 3'	APPROVE	DATE	PROJ.		Customer NO.
				DIM TOL	Steven Zhao	2025/09/16			

WCON
Http: www.wcon.com

WCON-Dongguan Tel: +86 769 85358920 Fax: +86 769 85358915 E-mail: sales@wcon.com	WCON-Kunshan Tel: +86 512 57468408 Fax: +86 512 57468468 E-mail: salesks@wcon.com
-------------------------------------------------------------------------------------------	--------------------------------------------------------------------------------------------

HSF

Table 1

Item	Pin Length	W	C	D	E	B	Mating	
Standard	9.3	5.0	5.0	0.1	5.5	2.0	2321/2320T	
	10.3					3.0	2334/2344/2346	
	10.8					3.5	2357	
	11.8					4.5	2345/2385	
	11.0	6.8	7.3	2.0	2321/2320T			
	12.0			3.0	2334/2344/2346			
	12.5			3.5	2357			
	13.5			4.5	2345/2385			
	11.8	7.6	8.1	2.0	2321/2320T			
	12.8			3.0	2334/2344/2346			
	13.3			3.5	2357			
	14.3			4.5	2345/2385			
	13.3	9.0	9.5	2.0	2321/2320T			
	14.3			3.0	2334/2344/2346			
	14.8			3.5	2357			
	15.8			4.5	2345/2385			
	14.3	10.1	10.6	2.0	2321/2320T			
	15.3			3.0	2334/2344/2346			
	15.8			3.5	2357			
	16.8			4.5	2345/2385			
	16.0	11.9	12.4	2.0	2321/2320T			
	17.0			3.0	2334/2344/2346			
	17.5			3.5	2357			
	18.5			4.5	2345/2385			
	Alternate							

Packaging Quantity Refers To The Following Table

PINS /Row	Q' ty/Tube	Q' ty/Inner Box	Q' ty/Box
4	107	6,420	12,840
5	87	5,220	10,440
6	73	4,380	8,760
7	63	3,780	7,560
8	55	3,300	6,600
9	49	2,940	5,880
10	44	2,640	5,280
11	40	2,400	4,800
12	37	2,220	4,440
13	34	2,040	4,080
14	32	1,920	3,840
15	29	1,740	3,480
16	28	1,680	3,360
17	26	1,560	3,120
18	25	1,500	3,000
19	23	1,380	2,760
20	22	1,320	2,640
21	21	1,260	2,520
22	20	1,200	2,400
23	19	1,140	2,280
24	18	1,080	2,160
25	18	1,080	2,160
26	17	1,020	2,040
27	16	960	1,920

PINS /Row	Q' ty/Tube	Q' ty/Inner Box	Q' ty/Box
28	16	960	1,920
29	15	900	1,800
30	15	900	1,800
31	14	840	1,680
32	14	840	1,680
33	13	780	1,560
34	13	780	1,560
35	12	720	1,440
36	12	720	1,440
37	12	720	1,440
38	11	660	1,320
39	11	660	1,320
40	11	660	1,320
41	11	660	1,320
42	10	600	1,200
43	10	600	1,200
44	10	600	1,200
45	10	600	1,200
46	9	540	1,080
47	9	540	1,080
48	9	540	1,080
49	9	540	1,080
50	9	540	1,080

C=5.0,B=2.0				
PINS /ROW	W	Q' ty/Reel	Q' ty/Inner Box	Q' ty/Box
2	16	380	1,520	4,560
3	24	380	1,140	3,420
4	24	380	1,140	3,420
5	24	380	1,140	3,420
6	24	380	1,140	3,420
7	24	380	1,140	3,420
8	24	380	1,140	3,420
9	24	380	1,140	3,420
10	32	380	760	2,280
11	32	380	760	2,280
12	32	380	760	2,280
13	44	380	760	2,280
14	44	380	760	2,280
15	44	380	760	2,280
16	44	380	760	2,280
17	44	380	760	2,280
18	44	380	760	2,280
19	44	380	760	2,280
20	44	380	760	2,280
21	44	380	760	2,280
22	56	380	380	1,140
23	56	380	380	1,140
24	56	380	380	1,140
25	56	380	380	1,140
26	56	380	380	1,140

C=5.0,B=2.0				
PINS /ROW	W	Q' ty/Reel	Q' ty/Inner Box	Q' ty/Box
27	56	380	380	1,140
28	56	380	380	1,140
29	56	380	380	1,140
30	56	380	380	1,140
31	72	380	380	1,140
32	72	380	380	1,140
33	72	380	380	1,140
34	72	380	380	1,140
35	72	380	380	1,140
36	72	380	380	1,140
37	72	380	380	1,140
38	72	380	380	1,140
39	72	380	380	1,140
40	72	380	380	1,140
41	72	380	380	1,140
42	72	380	380	1,140
43	72	380	380	1,140
44	88	380	380	1,140
45	88	380	380	1,140
46	88	380	380	1,140
47	88	380	380	1,140
48	88	380	380	1,140
49	88	380	380	1,140
50	88	380	380	1,140

A4	2025/09/16	Standardization Drawing	CP	OPERATION	DRAW	DATE	SCALE	Fit	PART NO. 1325-22XXXXMXXCXXX Δ
A3	2023/02/02	Add Flatness	Du Ying	x.X ± 0.40	CP	2025/09/16	UNIT	mm [inch]	
A2	2021/12/28	MODIFY CAP	Du Ying	x.XX ± 0.25	CHECK	DATE	SIZE	A4	
A0	2012/03/31	NEW	-----	x.XXX ± 0.15	TANG	2025/09/16	SHEET	3/9	
REV	DATE	MODIFICATION DESCRIPTION	CHANGE	Angle $\pm 3'$	APPROVE	DATE	PROJ.	ϕ \perp	TITLE: 1.27 Pin Header, DUAL ROW, SMT, DOUBLE PLASTIC, WITHOUT POST, H=2.5
				DIM TOL	Steven Zhao	2025/09/16			Customer NO.



WCON-Dongguan Tel: +86 769 85358920 Fax: +86 769 85358915 E-mail: sales@wcon.com

WCON-Kunshan Tel: +86 512 57468408 Fax: +86 512 57468468 E-mail: salesks@wcon.com

HSF

Packaging Quantity Refers To The Following Table

C=5.0,B=3.0/3.5

PINS /Row	W	Q' ty/Reel	Q' ty/Inner Box	Q' ty/Box
2	24	330	990	2,970
3	24	330	990	2,970
4	24	330	990	2,970
5	24	330	990	2,970
6	24	330	990	2,970
7	24	330	990	2,970
8	24	330	990	2,970
9	32	330	660	1,980
10	32	330	660	1,980
11	32	330	660	1,980
12	44	330	660	1,980
13	44	330	660	1,980
14	44	330	660	1,980
15	44	330	660	1,980
16	44	330	660	1,980
17	44	330	660	1,980
18	44	330	660	1,980
19	44	330	660	1,980
20	44	330	660	1,980
21	56	330	330	990
22	56	330	330	990
23	56	330	330	990
24	56	330	330	990
25	56	330	330	990
26	56	330	330	990

C=5.0,B=3.0/3.5

PINS /Row	W	Q' ty/Reel	Q' ty/Inner Box	Q' ty/Box
27	56	330	330	990
28	56	330	330	990
29	56	330	330	990
30	72	330	330	990
31	72	330	330	990
32	72	330	330	990
33	72	330	330	990
34	72	330	330	990
35	72	330	330	990
36	72	330	330	990
37	72	330	330	990
38	72	330	330	990
39	72	330	330	990
40	72	330	330	990
41	72	330	330	990
42	72	330	330	990
43	88	330	330	990
44	88	330	330	990
45	88	330	330	990
46	88	330	330	990
47	88	330	330	990
48	88	330	330	990
49	88	330	330	990
50	88	330	330	990

C=5.0,B=4.5

PINS /Row	W	Q' ty/Reel	Q' ty/Inner Box	Q' ty/Box
2	24	290	870	2,610
3	24	290	870	2,610
4	24	290	870	2,610
5	24	290	870	2,610
6	24	290	870	2,610
7	24	290	870	2,610
8	32	290	580	1,740
9	32	290	580	1,740
10	32	290	580	1,740
11	44	290	580	1,740
12	44	290	580	1,740
13	44	290	580	1,740
14	44	290	580	1,740
15	44	290	580	1,740
16	44	290	580	1,740
17	44	290	580	1,740
18	44	290	580	1,740
19	44	290	580	1,740
20	56	290	290	870
21	56	290	290	870
22	56	290	290	870
23	56	290	290	870
24	56	290	290	870
25	56	290	290	870
26	56	290	290	870

C=5.0,B=4.5

PINS /Row	W	Q' ty/Reel	Q' ty/Inner Box	Q' ty/Box
27	56	290	290	870
28	56	290	290	870
29	56	290	290	870
30	72	290	290	870
31	72	290	290	870
32	72	290	290	870
33	72	290	290	870
34	72	290	290	870
35	72	290	290	870
36	72	290	290	870
37	72	290	290	870
38	72	290	290	870
39	72	290	290	870
40	72	290	290	870
41	72	290	290	870
42	88	290	290	870
43	88	290	290	870
44	88	290	290	870
45	88	290	290	870
46	88	290	290	870
47	88	290	290	870
48	88	290	290	870
49	88	290	290	870
50	88	290	290	870

A4	2025/09/16	Standardization Drawing	CP	OPERATION	DRAW	DATE	SCALE	Fit	PART NO.
A3	2023/02/02	Add Flatness	Du Ying	x.X ±0.40	CP	2025/09/16	UNIT	mm [inch]	1325-22XXXXMXXCXXX
A2	2021/12/28	MODIFY CAP	Du Ying	x.XX ±0.25	CHECK	DATE	SIZE	A4	TITLE:
A0	2012/03/31	NEW	-----	x.XXX ±0.15	TANG	2025/09/16	SHEET	4/9	1.27 Pin Header, DUAL ROW, SMT, DOUBLE PLASTIC, WITHOUT POST, H=2.5
REV	DATE	MODIFICATION DESCRIPTION	CHANGE	Angle ± 3'	APPROVE	DATE	PROJ.		Customer NO.
				DIM TOL	Steven Zhao	2025/09/16			



Http: www.wcon.com

WCON-Dongguan Tel: +86 769 85358920 Fax: +86 769 85358915 E-mail: sales@wcon.com	WCON-Kunshan Tel: +86 512 57468408 Fax: +86 512 57468468 E-mail: salesks@wcon.com
-------------------------------------------------------------------------------------------	--------------------------------------------------------------------------------------------

HSF

Packaging Quantity Refers To The Following Table

C=6.8,B=2.0/3.0/3.5

PINS /Row	W	Q' ty/Reel	Q' ty/Inner Box	Q' ty/Box
2	24	290	870	2,610
3	24	290	870	2,610
4	24	290	870	2,610
5	24	290	870	2,610
6	24	290	870	2,610
7	24	290	870	2,610
8	32	290	580	1,740
9	32	290	580	1,740
10	32	290	580	1,740
11	44	290	580	1,740
12	44	290	580	1,740
13	44	290	580	1,740
14	44	290	580	1,740
15	44	290	580	1,740
16	44	290	580	1,740
17	44	290	580	1,740
18	44	290	580	1,740
19	44	290	580	1,740
20	56	290	290	870
21	56	290	290	870
22	56	290	290	870
23	56	290	290	870
24	56	290	290	870
25	56	290	290	870
26	56	290	290	870

C=6.8,B=2.0/3.0/3.5

PINS /Row	W	Q' ty/Reel	Q' ty/Inner Box	Q' ty/Box
27	56	290	290	870
28	56	290	290	870
29	56	290	290	870
30	72	290	290	870
31	72	290	290	870
32	72	290	290	870
33	72	290	290	870
34	72	290	290	870
35	72	290	290	870
36	72	290	290	870
37	72	290	290	870
38	72	290	290	870
39	72	290	290	870
40	72	290	290	870
41	72	290	290	870
42	88	290	290	870
43	88	290	290	870
44	88	290	290	870
45	88	290	290	870
46	88	290	290	870
47	88	290	290	870
48	88	290	290	870
49	88	290	290	870
50	88	290	290	870

C=6.8,B=4.5

PINS /Row	W	Q' ty/Reel	Q' ty/Inner Box	Q' ty/Box
2	24	250	750	2,250
3	24	250	750	2,250
4	24	250	750	2,250
5	24	250	750	2,250
6	24	250	750	2,250
7	32	250	500	1,500
8	32	250	500	1,500
9	32	250	500	1,500
10	44	250	500	1,500
11	44	250	500	1,500
12	44	250	500	1,500
13	44	250	500	1,500
14	44	250	500	1,500
15	44	250	500	1,500
16	44	250	500	1,500
17	44	250	500	1,500
18	44	250	500	1,500
19	56	250	250	750
20	56	250	250	750
21	56	250	250	750
22	56	250	250	750
23	56	250	250	750
24	56	250	250	750
25	56	250	250	750
26	56	250	250	750

C=6.8,B=4.5

PINS /Row	W	Q' ty/Reel	Q' ty/Inner Box	Q' ty/Box
27	56	250	250	750
28	72	250	250	750
29	72	250	250	750
30	72	250	250	750
31	72	250	250	750
32	72	250	250	750
33	72	250	250	750
34	72	250	250	750
35	72	250	250	750
36	72	250	250	750
37	72	250	250	750
38	72	250	250	750
39	72	250	250	750
40	72	250	250	750
41	88	250	250	750
42	88	250	250	750
43	88	250	250	750
44	88	250	250	750
45	88	250	250	750
46	88	250	250	750
47	88	250	250	750
48	88	250	250	750
49	88	250	250	750
50	88	250	250	750

A4	2025/09/16	Standardization Drawing	CP	OPERATION	DRAW	DATE	SCALE	Fit	PART NO.
A3	2023/02/02	Add Flatness	Du Ying	x.X ±0.40	CP	2025/09/16	UNIT	mm [inch]	1325-22XXXXMXXCXXX
A2	2021/12/28	MODIFY CAP	Du Ying	x.XX ±0.25	CHECK	DATE	SIZE	A4	TITLE:
A0	2012/03/31	NEW	-----	x.XXX ±0.15	TANG	2025/09/16	SHEET	5/9	1.27 Pin Header, DUAL ROW, SMT, DOUBLE PLASTIC, WITHOUT POST, H=2.5
REV	DATE	MODIFICATION DESCRIPTION	CHANGE	Angle ± 3'	APPROVE	DATE	PROJ.		Customer NO.
				DIM TOL	Steven Zhao	2025/09/16			



Http: www.wcon.com

WCON-Dongguan Tel: +86 769 85358920 Fax: +86 769 85358915 E-mail: sales@wcon.com	WCON-Kunshan Tel: +86 512 57468408 Fax: +86 512 57468468 E-mail: salesks@wcon.com
-------------------------------------------------------------------------------------------	--------------------------------------------------------------------------------------------

HSF

Packaging Quantity Refers To The Following Table

C=7.6,B=2.0

C=7.6,B=2.0

C=7.6,B=3.0/3.5/4.5

C=7.6,B=3.0/3.5/4.5

PINS /Row	W	Q' ty/Reel	Q' ty/Inner Box	Q' ty/Box
2	24	290	870	2,610
3	24	290	870	2,610
4	24	290	870	2,610
5	24	290	870	2,610
6	24	290	870	2,610
7	24	290	870	2,610
8	32	290	580	1,740
9	32	290	580	1,740
10	32	290	580	1,740
11	44	290	580	1,740
12	44	290	580	1,740
13	44	290	580	1,740
14	44	290	580	1,740
15	44	290	580	1,740
16	44	290	580	1,740
17	44	290	580	1,740
18	44	290	580	1,740
19	44	290	580	1,740
20	56	290	290	870
21	56	290	290	870
22	56	290	290	870
23	56	290	290	870
24	56	290	290	870
25	56	290	290	870
26	56	290	290	870

PINS /Row	W	Q' ty/Reel	Q' ty/Inner Box	Q' ty/Box
27	56	290	290	870
28	56	290	290	870
29	56	290	290	870
30	72	290	290	870
31	72	290	290	870
32	72	290	290	870
33	72	290	290	870
34	72	290	290	870
35	72	290	290	870
36	72	290	290	870
37	72	290	290	870
38	72	290	290	870
39	72	290	290	870
40	72	290	290	870
41	72	290	290	870
42	88	290	290	870
43	88	290	290	870
44	88	290	290	870
45	88	290	290	870
46	88	290	290	870
47	88	290	290	870
48	88	290	290	870
49	88	290	290	870
50	88	290	290	870

PINS /Row	W	Q' ty/Reel	Q' ty/Inner Box	Q' ty/Box
2	24	250	750	2,250
3	24	250	750	2,250
4	24	250	750	2,250
5	24	250	750	2,250
6	24	250	750	2,250
7	24	250	750	2,250
8	32	250	500	1,500
9	32	250	500	1,500
10	32	250	500	1,500
11	44	250	500	1,500
12	44	250	500	1,500
13	44	250	500	1,500
14	44	250	500	1,500
15	44	250	500	1,500
16	44	250	500	1,500
17	44	250	500	1,500
18	44	250	500	1,500
19	56	250	250	750
20	56	250	250	750
21	56	250	250	750
22	56	250	250	750
23	56	250	250	750
24	56	250	250	750
25	56	250	250	750
26	56	250	250	750

PINS /Row	W	Q' ty/Reel	Q' ty/Inner Box	Q' ty/Box
27	56	250	250	750
28	56	250	250	750
29	72	250	250	750
30	72	250	250	750
31	72	250	250	750
32	72	250	250	750
33	72	250	250	750
34	72	250	250	750
35	72	250	250	750
36	72	250	250	750
37	72	250	250	750
38	72	250	250	750
39	72	250	250	750
40	72	250	250	750
41	88	250	250	750
42	88	250	250	750
43	88	250	250	750
44	88	250	250	750
45	88	250	250	750
46	88	250	250	750
47	88	250	250	750
48	88	250	250	750
49	88	250	250	750
50	88	250	250	750

A4	2025/09/16	Standardization Drawing	CP	OPERATION	DRAW	DATE	SCALE	Fit	PART NO.
A3	2023/02/02	Add Flatness	Du Ying	x.X ±0.40	CP	2025/09/16	UNIT	mm [inch]	1325-22XXXXMXXCXXX
A2	2021/12/28	MODIFY CAP	Du Ying	x.XX ±0.25	CHECK	DATE	SIZE	A4	TITLE:
A0	2012/03/31	NEW	-----	x.XXX ±0.15	TANG	2025/09/16	SHEET	6/9	1.27 Pin Header, DUAL ROW, SMT, DOUBLE PLASTIC, WITHOUT POST, H=2.5
REV	DATE	MODIFICATION DESCRIPTION	CHANGE	Angle ± 3'	APPROVE	DATE	PROJ.		Customer NO.
				DIM TOL	Steven Zhao	2025/09/16			



Http: www.wcon.com

WCON-Dongguan Tel: +86 769 85358920 Fax: +86 769 85358915 E-mail: sales@wcon.com	WCON-Kunshan Tel: +86 512 57468408 Fax: +86 512 57468468 E-mail: sales@wcon.com
-------------------------------------------------------------------------------------------	------------------------------------------------------------------------------------------

HSF

Packaging Quantity Refers To The Following Table

C=9.0,B=2.0/3.0

C=9.0,B=2.0/3.0

C=9.0,B=3.5/4.5

C=9.0,B=3.5/4.5

PINS /Row	W	Q' ty/Reel	Q' ty/Inner Box	Q' ty/Box
2	24	250	750	2,250
3	24	250	750	2,250
4	24	250	750	2,250
5	24	250	750	2,250
6	24	250	750	2,250
7	32	250	500	1,500
8	32	250	500	1,500
9	32	250	500	1,500
10	44	250	500	1,500
11	44	250	500	1,500
12	44	250	500	1,500
13	44	250	500	1,500
14	44	250	500	1,500
15	44	250	500	1,500
16	44	250	500	1,500
17	44	250	500	1,500
18	44	250	500	1,500
19	56	250	250	750
20	56	250	250	750
21	56	250	250	750
22	56	250	250	750
23	56	250	250	750
24	56	250	250	750
25	56	250	250	750
26	56	250	250	750

PINS /Row	W	Q' ty/Reel	Q' ty/Inner Box	Q' ty/Box
27	56	250	250	750
28	72	250	250	750
29	72	250	250	750
30	72	250	250	750
31	72	250	250	750
32	72	250	250	750
33	72	250	250	750
34	72	250	250	750
35	72	250	250	750
36	72	250	250	750
37	72	250	250	750
38	72	250	250	750
39	72	250	250	750
40	72	250	250	750
41	88	250	250	750
42	88	250	250	750
43	88	250	250	750
44	88	250	250	750
45	88	250	250	750
46	88	250	250	750
47	88	250	250	750
48	88	250	250	750
49	88	250	250	750
50	88	250	250	750

PINS /Row	W	Q' ty/Reel	Q' ty/Inner Box	Q' ty/Box
2	24	210	630	1,890
3	24	210	630	1,890
4	24	210	630	1,890
5	24	210	630	1,890
6	24	210	630	1,890
7	32	210	420	1,260
8	32	210	420	1,260
9	32	210	420	1,260
10	44	210	420	1,260
11	44	210	420	1,260
12	44	210	420	1,260
13	44	210	420	1,260
14	44	210	420	1,260
15	44	210	420	1,260
16	44	210	420	1,260
17	44	210	420	1,260
18	56	210	210	630
19	56	210	210	630
20	56	210	210	630
21	56	210	210	630
22	56	210	210	630
23	56	210	210	630
24	56	210	210	630
25	56	210	210	630
26	56	210	210	630

PINS /Row	W	Q' ty/Reel	Q' ty/Inner Box	Q' ty/Box
27	72	210	210	630
28	72	210	210	630
29	72	210	210	630
30	72	210	210	630
31	72	210	210	630
32	72	210	210	630
33	72	210	210	630
34	72	210	210	630
35	72	210	210	630
36	72	210	210	630
37	72	210	210	630
38	72	210	210	630
39	72	210	210	630
40	88	210	210	630
41	88	210	210	630
42	88	210	210	630
43	88	210	210	630
44	88	210	210	630
45	88	210	210	630
46	88	210	210	630
47	88	210	210	630
48	88	210	210	630
49	88	210	210	630
50	88	210	210	630

A4	2025/09/16	Standardization Drawing	CP	OPERATION	DRAW	DATE	SCALE	Fit	PART NO.
A3	2023/02/02	Add Flatness	Du Ying	x.X ±0.40	CP	2025/09/16	UNIT	mm [inch]	1325-22XXXXMXXCXXX
A2	2021/12/28	MODIFY CAP	Du Ying	x.XX ±0.25	CHECK	DATE	SIZE	A4	TITLE:
A0	2012/03/31	NEW	-----	x.XXX ±0.15	TANG	2025/09/16	SHEET	7/9	1.27 Pin Header, DUAL ROW, SMT, DOUBLE PLASTIC, WITHOUT POST, H=2.5
REV	DATE	MODIFICATION DESCRIPTION	CHANGE	Angle ± 3'	APPROVE	DATE	PROJ.		Customer NO.
				DIM TOL	Steven Zhao	2025/09/16			



Http: www.wcon.com

WCON-Dongguan Tel: +86 769 85358920 Fax: +86 769 85358915 E-mail: sales@wcon.com	WCON-Kunshan Tel: +86 512 57468408 Fax: +86 512 57468468 E-mail: sales@wcon.com
-------------------------------------------------------------------------------------------	------------------------------------------------------------------------------------------

HSF

Packaging Quantity Refers To The Following Table

C=10.1,B=2.0/3.0/3.5

PINS /Row	W	Q' ty/Reel	Q' ty/Inner Box	Q' ty/Box
2	24	210	630	1,890
3	24	210	630	1,890
4	24	210	630	1,890
5	24	210	630	1,890
6	24	210	630	1,890
7	32	210	420	1,260
8	32	210	420	1,260
9	32	210	420	1,260
10	44	210	420	1,260
11	44	210	420	1,260
12	44	210	420	1,260
13	44	210	420	1,260
14	44	210	420	1,260
15	44	210	420	1,260
16	44	210	420	1,260
17	44	210	420	1,260
18	56	210	210	630
19	56	210	210	630
20	56	210	210	630
21	56	210	210	630
22	56	210	210	630
23	56	210	210	630
24	56	210	210	630
25	56	210	210	630
26	56	210	210	630

C=10.1,B=2.0/3.0/3.5

PINS /Row	W	Q' ty/Reel	Q' ty/Inner Box	Q' ty/Box
27	72	210	210	630
28	72	210	210	630
29	72	210	210	630
30	72	210	210	630
31	72	210	210	630
32	72	210	210	630
33	72	210	210	630
34	72	210	210	630
35	72	210	210	630
36	72	210	210	630
37	72	210	210	630
38	72	210	210	630
39	72	210	210	630
40	88	210	210	630
41	88	210	210	630
42	88	210	210	630
43	88	210	210	630
44	88	210	210	630
45	88	210	210	630
46	88	210	210	630
47	88	210	210	630
48	88	210	210	630
49	88	210	210	630
50	88	210	210	630

C=10.1,B=4.5

PINS /Row	W	Q' ty/Reel	Q' ty/Inner Box	Q' ty/Box
2	24	170	510	1,530
3	24	170	510	1,530
4	24	170	510	1,530
5	24	170	510	1,530
6	32	170	340	1,020
7	32	170	340	1,020
8	32	170	340	1,020
9	32	170	340	1,020
10	44	170	340	1,020
11	44	170	340	1,020
12	44	170	340	1,020
13	44	170	340	1,020
14	44	170	340	1,020
15	44	170	340	1,020
16	44	170	340	1,020
17	56	170	170	510
18	56	170	170	510
19	56	170	170	510
20	56	170	170	510
21	56	170	170	510
22	56	170	170	510
23	56	170	170	510
24	56	170	170	510
25	56	170	170	510
26	72	170	170	510

C=10.1,B=4.5

PINS /Row	W	Q' ty/Reel	Q' ty/Inner Box	Q' ty/Box
27	72	170	170	510
28	72	170	170	510
29	72	170	170	510
30	72	170	170	510
31	72	170	170	510
32	72	170	170	510
33	72	170	170	510
34	72	170	170	510
35	72	170	170	510
36	72	170	170	510
37	72	170	170	510
38	72	170	170	510
39	88	170	170	510
40	88	170	170	510
41	88	170	170	510
42	88	170	170	510
43	88	170	170	510
44	88	170	170	510
45	88	170	170	510
46	88	170	170	510
47	88	170	170	510
48	88	170	170	510
49	88	170	170	510
50	88	170	170	510

A4	2025/09/16	Standardization Drawing	CP	OPERATION	DRAW	DATE	SCALE	Fit	PART NO.
A3	2023/02/02	Add Flatness	Du Ying	x.X ±0.40	CP	2025/09/16	UNIT	mm [inch]	1325-22XXXXMXXCXXX
A2	2021/12/28	MODIFY CAP	Du Ying	x.XX ±0.25	CHECK	DATE	SIZE	A4	TITLE:
A0	2012/03/31	NEW	-----	x.XXX ±0.15	TANG	2025/09/16	SHEET	8/9	1.27 Pin Header, DUAL ROW, SMT, DOUBLE PLASTIC, WITHOUT POST, H=2.5
REV	DATE	MODIFICATION DESCRIPTION	CHANGE	Angle ± 3'	APPROVE	DATE	PROJ.		Customer NO.
				DIM TOL	Steven Zhao	2025/09/16			



Http: www.wcon.com

WCON-Dongguan Tel: +86 769 85358920 Fax: +86 769 85358915 E-mail: sales@wcon.com	WCON-Kunshan Tel: +86 512 57468408 Fax: +86 512 57468468 E-mail: salesks@wcon.com
-------------------------------------------------------------------------------------------	--------------------------------------------------------------------------------------------

HSF

Packaging Quantity Refers To The Following Table

C=11.9,B=2.0/3.0

PINS /Row	W	Q' ty/Reel	Q' ty/Inner Box	Q' ty/Box
2	24	160	480	1,440
3	24	160	480	1,440
4	24	160	480	1,440
5	24	160	480	1,440
6	32	160	320	960
7	32	160	320	960
8	32	160	320	960
9	32	160	320	960
10	44	160	320	960
11	44	160	320	960
12	44	160	320	960
13	44	160	320	960
14	44	160	320	960
15	44	160	320	960
16	44	160	320	960
17	56	160	160	480
18	56	160	160	480
19	56	160	160	480
20	56	160	160	480
21	56	160	160	480
22	56	160	160	480
23	56	160	160	480
24	56	160	160	480
25	56	160	160	480
26	72	160	160	480

C=11.9,B=2.0/3.0

PINS /Row	W	Q' ty/Reel	Q' ty/Inner Box	Q' ty/Box
27	72	160	160	480
28	72	160	160	480
29	72	160	160	480
30	72	160	160	480
31	72	160	160	480
32	72	160	160	480
33	72	160	160	480
34	72	160	160	480
35	72	160	160	480
36	72	160	160	480
37	72	160	160	480
38	72	160	160	480
39	88	160	160	480
40	88	160	160	480
41	88	160	160	480
42	88	160	160	480
43	88	160	160	480
44	88	160	160	480
45	88	160	160	480
46	88	160	160	480
47	88	160	160	480
48	88	160	160	480
49	88	160	160	480
50	88	160	160	480

C=11.9,B=3.5/4.5

PINS /Row	W	Q' ty/Reel	Q' ty/Inner Box	Q' ty/Box
2	24	130	390	1,170
3	24	130	390	1,170
4	24	130	390	1,170
5	24	130	390	1,170
6	32	130	260	780
7	32	130	260	780
8	32	130	260	780
9	32	130	260	780
10	44	130	260	780
11	44	130	260	780
12	44	130	260	780
13	44	130	260	780
14	44	130	260	780
15	44	130	260	780
16	56	130	130	390
17	56	130	130	390
18	56	130	130	390
19	56	130	130	390
20	56	130	130	390
21	56	130	130	390
22	56	130	130	390
23	56	130	130	390
24	56	130	130	390
25	56	130	130	390
26	72	130	130	390

C=11.9,B=3.5/4.5

PINS /Row	W	Q' ty/Reel	Q' ty/Inner Box	Q' ty/Box
27	72	130	130	390
28	72	130	130	390
29	72	130	130	390
30	72	130	130	390
31	72	130	130	390
32	72	130	130	390
33	72	130	130	390
34	72	130	130	390
35	72	130	130	390
36	72	130	130	390
37	72	130	130	390
38	88	130	130	390
39	88	130	130	390
40	88	130	130	390
41	88	130	130	390
42	88	130	130	390
43	88	130	130	390
44	88	130	130	390
45	88	130	130	390
46	88	130	130	390
47	88	130	130	390
48	88	130	130	390
49	88	130	130	390
50	88	130	130	390

A4	2025/09/16	Standardization Drawing	CP	OPERATION	DRAW	DATE	SCALE	Fit	PART NO.
A3	2023/02/02	Add Flatness	Du Ying	x.X ±0.40	CP	2025/09/16	UNIT	mm [inch]	1325-22XXXXMXXCXXX
A2	2021/12/28	MODIFY CAP	Du Ying	x.XX ±0.25	CHECK	DATE	SIZE	A4	TITLE:
A0	2012/03/31	NEW	-----	x.XXX ±0.15	TANG	2025/09/16	SHEET	9/9	1.27 Pin Header, DUAL ROW, SMT, DOUBLE PLASTIC, WITHOUT POST, H=2.5
REV	DATE	MODIFICATION DESCRIPTION	CHANGE	Angle ± 3'	APPROVE	DATE	PROJ.		Customer NO.
				DIM TOL	Steven Zhao	2025/09/16			



Http: www.wcon.com

WCON-Dongguan Tel: +86 769 85358920 Fax: +86 769 85358915 E-mail: sales@wcon.com	WCON-Kunshan Tel: +86 512 57468408 Fax: +86 512 57468468 E-mail: sales@wcon.com
-------------------------------------------------------------------------------------------	------------------------------------------------------------------------------------------