

HSF

NOTES:

Rated Current: 1.5AMP. (20°C, 2*2P-2*15P)
 1.0AMP. (20°C, 2*16P-2*50P) \triangle
 Contact Resistance: 20m Ω Max.
 Withstand Voltage: 500V AC/DC
 Insulation Resistance: 1000M Ω Min.
 Operation Temperature: -40°C to +125°C (Gold Plating)
 -40°C to +105°C (Tin Plating) \triangle

Contact Material: Copper Alloy
 Contact Plating: Au or Sn Over Ni
 Insulator Material: PA9T+G.F UL94V-0 BK \triangle

Ordering Information

1425-2 2 XX XX M XXX C R XX \triangle

Plastic Layer
 Plastic Row
 No. of Pins
 Per Row: 02-50
 Contact Plating
 G0=Gold Flash
 G3=10u"Au, BG3=8u"PdNi+2u"Au
 G4=15u"Au, BG4=13u"PdNi+2u"Au
 G5=30u"Au, BG5=28u"PdNi+2u"Au
 S0=Gold Flash/Tin
 S3=10u"Au/Sn, P3=8u"PdNi+2u"Au/Sn
 S4=15u"Au/Sn, P4=13u"PdNi+2u"Au/Sn
 S5=30u"Au/Sn, P5=28u"PdNi+2u"Au/Sn
 SN=Bright Tin
 SM=Matte Tin

Series No.
 01-99
 Packing
 T=Tube
 P=Tube+CAP
 R=Tape&Reel+CAP
 Insulator Material
 C=PA9T(Standard)
 Pin Length
 L(See Table)
 Type:
 M=SMT

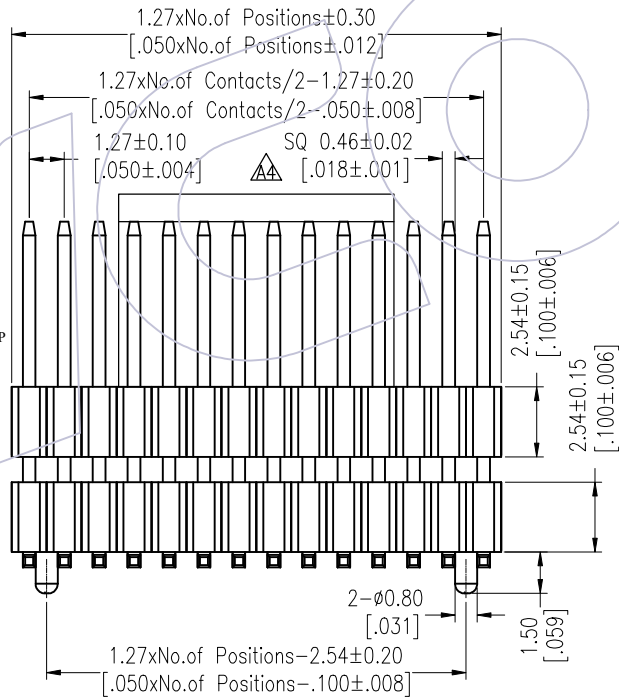
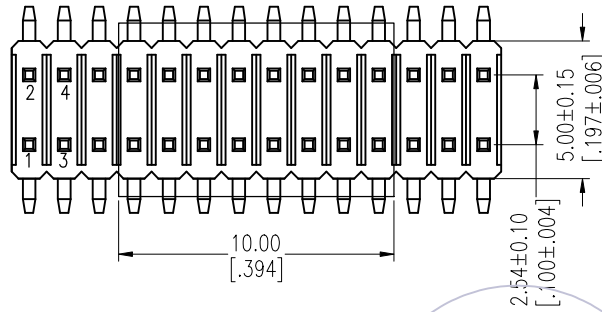

Recommended P.C.B Layout (Top Side)
 (PCB BOARD TOLERANCE±0.05)
 (PCB Thickness: T=1.60m)

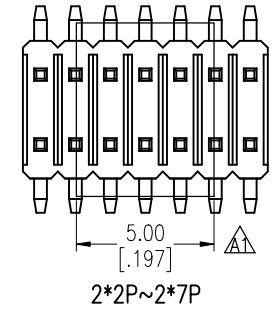
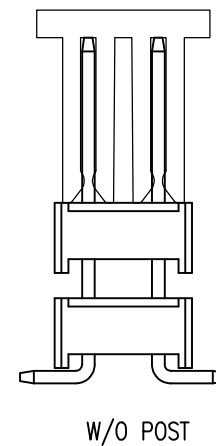
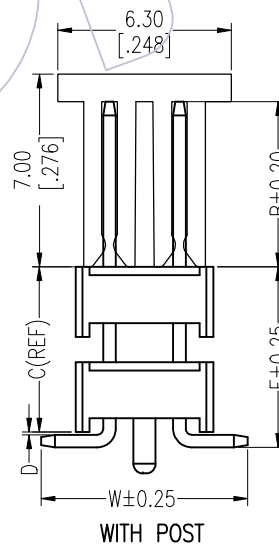
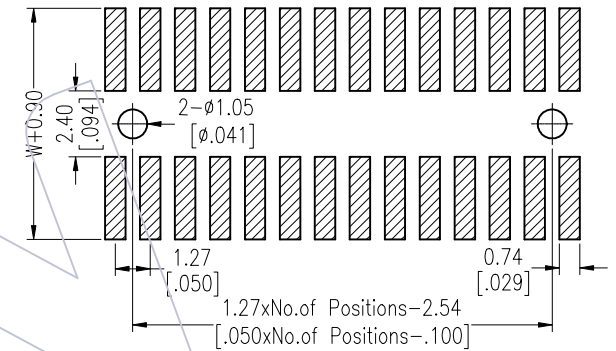

\triangle	PIN(PerRow)	2-15P	16-30P	31-50P
	M	0.10	0.12	0.15

A4	2025/12/23	Standardization Drawing	CP	OPERATION	DRAW	DATE	SCALE	Fit	PART NO. 1425-22XXXXMXXXCXXX \triangle TITLE: 1.27*2.54 Pin Header, DUAL ROW, SMT, DOUBLE PLASTIC, H=2.54 Customer NO.
A3	2023/02/02	Add Flatness	Du Ying	X.X ±0.40	CP	2025/12/23	UNIT	mm [inch]	
A2	2018/01/12	MODIFY PART NO.	William Chen	X.XX ±0.25	CHECK	DATE	SIZE	A4	
A0	2012/04/06	NEW	-----	X.XXX ±0.15	TANG	2025/12/23	SHEET	1/5	
REV	DATE	MODIFICATION DESCRIPTION	CHANGE	Angle ± 3'	APPROVE	DATE	PROJ.	ϕ	

WCON
 Http: www.wcon.com

WCON-Dongguan
 Tel: +86 769 85358920
 Fax: +86 769 85358915
 E-mail: sales@wcon.com

WCON-Kunshan
 Tel: +86 512 57468408
 Fax: +86 512 57468468
 E-mail: sales@wcon.com

HSF

Packing:

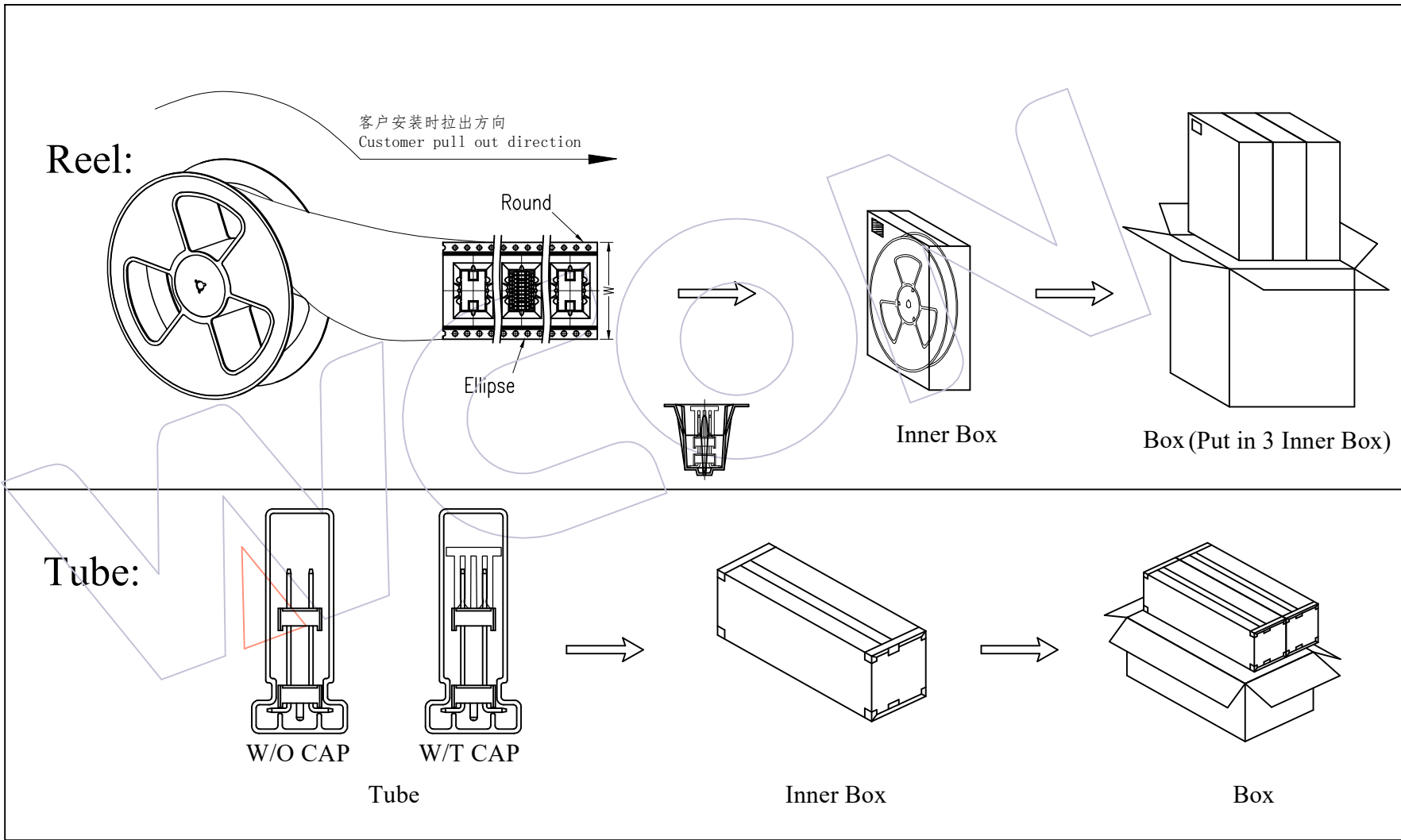

A4	2025/12/23	Standardization Drawing	CP	OPERATION	DRAW	DATE	SCALE	Fit	PART NO. 1425-22XXXXMXXXCXXX
A3	2023/02/02	Add Flatness	Du Ying	X.X ±0.40	CP	2025/12/23	UNIT	mm [inch]	
A2	2018/01/12	MODIFY PART NO.	William Chen	X.XX ±0.25	CHECK	DATE	SIZE	A4	
A0	2012/04/06	NEW	-----	X.XXX ±0.15	TANG	2025/12/23	SHEET	2/5	
REV	DATE	MODIFICATION DESCRIPTION	CHANGE	Angle ± 3'	APPROVE	DATE	PROJ.		
				DIM TOL	Steven Zhao	2025/12/23			TITLE: 1.27*2.54 Pin Header, DUAL ROW, SMT, DOUBLE PLASTIC, H=2.54
									Customer NO.

WCON
Http: www.wcon.com

WCON-Dongguan
Tel: +86 769 85358920
Fax: +86 769 85358915
E-mail: sales@wcon.com

WCON-Kunshan
Tel: +86 512 57468408
Fax: +86 512 57468468
E-mail: salesks@wcon.com

HSF

Packaging Quantity Refers To The Following Table

Table 1

Item	Pin Length	W	C	D	E	B	Mating		
Standard	9.5	5.08	0	5.54	2.0	2321/2320T			
	10.5					3.0 2334/2344/2346			
	11.0					3.5 2357			
	12.0					4.5 2345/2385			
	11.0					6.4	0.1	6.96	2.0 2321/2320T
	12.0								3.0 2334/2344/2346
	12.5	3.5 2357							
	13.5	4.5 2345/2385							
	14.5	7.5	9.8	0.3	10.56				2.0 2321/2320T
	15.5								3.0 2334/2344/2346
	16.0	3.5 2357							
	17.0	4.5 2345/2385							
	16.0	11.4	0.1	11.96	2.0 2321/2320T				
	17.0				3.0 2334/2344/2346				
	17.5				3.5 2357				
	18.5				4.5 2345/2385				
	Alternate								

PINS /Row	Q' ty/Tube	Q' ty/Inner Box	Q' ty/Box
4	114	6,840	13,680
5	91	5,460	10,920
6	76	4,560	9,120
7	65	3,900	7,800
8	57	3,420	6,840
9	50	3,000	6,000
10	45	2,700	5,400
11	41	2,460	4,920
12	38	2,280	4,560
13	35	2,100	4,200
14	32	1,920	3,840
15	30	1,800	3,600
16	28	1,680	3,360
17	26	1,560	3,120
18	25	1,500	3,000
19	24	1,440	2,880
20	22	1,320	2,640
21	21	1,260	2,520
22	20	1,200	2,400
23	19	1,140	2,280
24	19	1,140	2,280
25	18	1,080	2,160
26	17	1,020	2,040
27	16	960	1,920

PINS /Row	Q' ty/Tube	Q' ty/Inner Box	Q' ty/Box
28	16	960	1,920
29	15	900	1,800
30	15	900	1,800
31	14	840	1,680
32	14	840	1,680
33	13	780	1,560
34	13	780	1,560
35	13	780	1,560
36	12	720	1,440
37	12	720	1,440
38	12	720	1,440
39	11	660	1,320
40	11	660	1,320
41	11	660	1,320
42	10	600	1,200
43	10	600	1,200
44	10	600	1,200
45	10	600	1,200
46	9	540	1,080
47	9	540	1,080
48	9	540	1,080
49	9	540	1,080
50	9	540	1,080

A4	2025/12/23	Standardization Drawing	CP	OPERATION	DRAW	DATE	SCALE	Fit	PART NO.
A3	2023/02/02	Add Flatness	Du Ying	x.X ±0.40	CP	2025/12/23	UNIT	mm [inch]	1425-22XXXXMXXCXXX
A2	2018/01/12	MODIFY PART NO.	William Chen	x.XX ±0.25	CHECK	DATE	SIZE	A4	TITLE:
A0	2012/04/06	NEW	-----	x.XXX ±0.15	TANG	2025/12/23	SHEET	3/5	1.27*2.54 Pin Header, DUAL ROW, SMT, DOUBLE PLASTIC, H=2.54
REV	DATE	MODIFICATION DESCRIPTION	CHANGE	Angle ± 3'	APPROVE	DATE	PROJ.		Customer NO.
				DIM TOL	Steven Zhao	2025/12/23			

WCON
Http: www.wcon.com

WCON-Dongguan Tel: +86 769 85358920 Fax: +86 769 85358915 E-mail: sales@wcon.com	WCON-Kunshan Tel: +86 512 57468408 Fax: +86 512 57468468 E-mail: sales@wcon.com
---	--

HSF

Packaging Quantity Refers To The Following Table

PINS /Row	W	Q' ty/Reel	Q' ty/Inner Box	Q' ty/Box	PINS /Row	W	Q' ty/Reel	Q' ty/Inner Box	Q' ty/Box	PINS /Row	W	Q' ty/Reel	Q' ty/Inner Box	Q' ty/Box	PINS /Row	W	Q' ty/Reel	Q' ty/Inner Box	Q' ty/Box
2	24	200	600	1,800	27	56	200	200	600	2	24	170	510	1,530	27	72	170	170	510
3	24	200	600	1,800	28	56	200	200	600	3	24	170	510	1,530	28	72	170	170	510
4	24	200	600	1,800	29	72	200	200	600	4	24	170	510	1,530	29	72	170	170	510
5	24	200	600	1,800	30	72	200	200	600	5	24	170	510	1,530	30	72	170	170	510
6	24	200	600	1,800	31	72	200	200	600	6	24	170	510	1,530	31	72	170	170	510
7	24	200	600	1,800	32	72	200	200	600	7	32	170	340	1,020	32	72	170	170	510
8	32	200	400	1,200	33	72	200	200	600	8	32	170	340	1,020	33	72	170	170	510
9	32	200	400	1,200	34	72	200	200	600	9	32	170	340	1,020	34	72	170	170	510
10	32	200	400	1,200	35	72	200	200	600	10	44	170	340	1,020	35	72	170	170	510
11	44	200	400	1,200	36	72	200	200	600	11	44	170	340	1,020	36	72	170	170	510
12	44	200	400	1,200	37	72	200	200	600	12	44	170	340	1,020	37	72	170	170	510
13	44	200	400	1,200	38	72	200	200	600	13	44	170	340	1,020	38	72	170	170	510
14	44	200	400	1,200	39	72	200	200	600	14	44	170	340	1,020	39	72	170	170	510
15	44	200	400	1,200	40	72	200	200	600	15	44	170	340	1,020	40	88	170	170	510
16	44	200	400	1,200	41	88	200	200	600	16	44	170	340	1,020	41	88	170	170	510
17	44	200	400	1,200	42	88	200	200	600	17	44	170	340	1,020	42	88	170	170	510
18	44	200	400	1,200	43	88	200	200	600	18	56	170	170	510	43	88	170	170	510
19	56	200	200	600	44	88	200	200	600	19	56	170	170	510	44	88	170	170	510
20	56	200	200	600	45	88	200	200	600	20	56	170	170	510	45	88	170	170	510
21	56	200	200	600	46	88	200	200	600	21	56	170	170	510	46	88	170	170	510
22	56	200	200	600	47	88	200	200	600	22	56	170	170	510	47	88	170	170	510
23	56	200	200	600	48	88	200	200	600	23	56	170	170	510	48	88	170	170	510
24	56	200	200	600	49	88	200	200	600	24	56	170	170	510	49	88	170	170	510
25	56	200	200	600	50	88	200	200	600	25	56	170	170	510	50	88	170	170	510
26	56	200	200	600						26	56	170	170	510					

A4	2025/12/23	Standardization Drawing	CP	OPERATION	DRAW	DATE	SCALE	Fit	PART NO.	 Http: www.wcon.com WCON-Dongguan Tel: +86 769 85358920 WCON-Kunshan Tel: +86 512 57468408 Fax: +86 769 85358915 Fax: +86 512 57468468 E-mail: sales@wcon.com E-mail: salesks@wcon.com
A3	2023/02/02	Add Flatness	Du Ying	X.X ±0.40	CP	2025/12/23	UNIT	mm [inch]	1425-22XXXXMXXXCXXX 	
A2	2018/01/12	MODIFY PART NO.	William Chen	X.XX ±0.25	CHECK	DATE	SIZE	A4	TITLE:	
A0	2012/04/06	NEW	-----	X.XXX ±0.15	TANG	2025/12/23	SHEET	4/5	1.27*2.54 Pin Header, DUAL ROW, SMT, DOUBLE PLASTIC, H=2.54	
REV	DATE	MODIFICATION DESCRIPTION	CHANGE	Angle ± 3'	APPROVE	DATE	PROJ.		Customer NO.	
				DIM TOL	Steven Zhao	2025/12/23				

HSF

Packaging Quantity Refers To The Following Table

PINS /Row	W	Q' ty/Reel	Q' ty/Inner Box	Q' ty/Box
2	24	130	390	1,170
3	24	130	390	1,170
4	24	130	390	1,170
5	32	130	260	780
6	32	130	260	780
7	32	130	260	780
8	32	130	260	780
9	32	130	260	780
10	44	130	260	780
11	44	130	260	780
12	44	130	260	780
13	44	130	260	780
14	44	130	260	780
15	44	130	260	780
16	56	130	130	390
17	56	130	130	390
18	56	130	130	390
19	56	130	130	390
20	56	130	130	390
21	56	130	130	390
22	56	130	130	390
23	56	130	130	390
24	56	130	130	390
25	56	130	130	390
26	72	130	130	390

PINS /Row	W	Q' ty/Reel	Q' ty/Inner Box	Q' ty/Box
27	72	130	130	390
28	72	130	130	390
29	72	130	130	390
30	72	130	130	390
31	72	130	130	390
32	72	130	130	390
33	72	130	130	390
34	72	130	130	390
35	72	130	130	390
36	72	130	130	390
37	72	130	130	390
38	88	130	130	390
39	88	130	130	390
40	88	130	130	390
41	88	130	130	390
42	88	130	130	390
43	88	130	130	390
44	88	130	130	390
45	88	130	130	390
46	88	130	130	390
47	88	130	130	390
48	88	130	130	390
49	88	130	130	390
50	88	130	130	390

PINS /Row	W	Q' ty/Reel	Q' ty/Inner Box	Q' ty/Box
2	24	110	330	990
3	24	110	330	990
4	24	110	330	990
5	32	110	220	660
6	32	110	220	660
7	32	110	220	660
8	32	110	220	660
9	44	110	220	660
10	44	110	220	660
11	44	110	220	660
12	44	110	220	660
13	44	110	220	660
14	44	110	220	660
15	56	110	110	330
16	56	110	110	330
17	56	110	110	330
18	56	110	110	330
19	56	110	110	330
20	56	110	110	330
21	56	110	110	330
22	56	110	110	330
23	56	110	110	330
24	56	110	110	330
25	72	110	110	330

PINS /Row	W	Q' ty/Reel	Q' ty/Inner Box	Q' ty/Box
26	72	110	110	330
27	72	110	110	330
28	72	110	110	330
29	72	110	110	330
30	72	110	110	330
31	72	110	110	330
32	72	110	110	330
33	72	110	110	330
34	72	110	110	330
35	72	110	110	330
36	72	110	110	330
37	72	110	110	330
38	88	110	110	330
39	88	110	110	330
40	88	110	110	330
41	88	110	110	330
42	88	110	110	330
43	88	110	110	330
44	88	110	110	330
45	88	110	110	330
46	88	110	110	330
47	88	110	110	330
48	88	110	110	330
49	88	110	110	330

A4	2025/12/23	Standardization Drawing	CP	OPERATION	DRAW	DATE	SCALE	Fit	PART NO.
A3	2023/02/02	Add Flatness	Du Ying	X.X ±0.40	CP	2025/12/23	UNIT	mm [inch]	1425-22XXXXMXXXCXXX
A2	2018/01/12	MODIFY PART NO.	William Chen	X.XX ±0.25	CHECK	DATE	SIZE	A4	TITLE:
A0	2012/04/06	NEW	-----	X.XXX ±0.15	TANG	2025/12/23	SHEET	5/5	1.27*2.54 Pin Header, DUAL ROW, SMT, DOUBLE PLASTIC, H=2.54
REV	DATE	MODIFICATION DESCRIPTION	CHANGE	Angle ± 3'	APPROVE	DATE	PROJ.		Customer NO.
				DIM TOL	Steven Zhao	2025/12/23			



WCON-Dongguan Tel: +86 769 85358920 Fax: +86 769 85358915 E-mail: sales@wcon.com	WCON-Kunshan Tel: +86 512 57468408 Fax: +86 512 57468468 E-mail: salesks@wcon.com
---	--