

HSF

NOTES:

Rated Current: 3.0AMP.(20°C,2*2P-2*15P)
 2.0AMP.(20°C,2*16P-2*40P) $\triangle A3$
 Contact Resistance: 20m Ω Max.
 Withstand Voltage: 500V AC/DC
 Insulation Resistance: 1000M Ω Min.
 Operation Temperature: -40°C to +125°C(Gold Plating)
 -40°C to +105°C(Tin Plating) $\triangle A3$
 Contact Material: Copper Alloy
 Contact Plating: Au or Sn Over 30u" Min Ni $\triangle A3$
 Insulator Material: PA9T+G.F UL94V-0 BK $\triangle A3$

Ordering Information

1220- 2 2 XX XX M XXX C R XX $\triangle A1$

Plastic Layer
 Plastic Row
 No. of Pins
 Per Row: 02-40
 Contact Plating
 G0=Gold Flash
 G3=10u"Au, BG3=8u"PdNi+2u"Au
 G4=15u"Au, BG4=13u"PdNi+2u"Au
 G5=30u"Au, BG5=28u"PdNi+2u"Au
 S0=Gold Flash/Tin
 S3=10u"Au/Sn, P3=8u"PdNi+2u"Au/Sn
 S4=15u"Au/Sn, P4=13u"PdNi+2u"Au/Sn
 S5=30u"Au/Sn, P5=28u"PdNi+2u"Au/Sn $\triangle A3$
 SN=Bright Tin
 SM=Matte Tin
 Series No. 01-99
 Packing
 T=Tube
 P=Tube+CAP
 R=Tape&Reel+CAP
 Insulator Material
 C=PA9T
 Pin Length
 L(See Table)
 Type:
 M:SMT

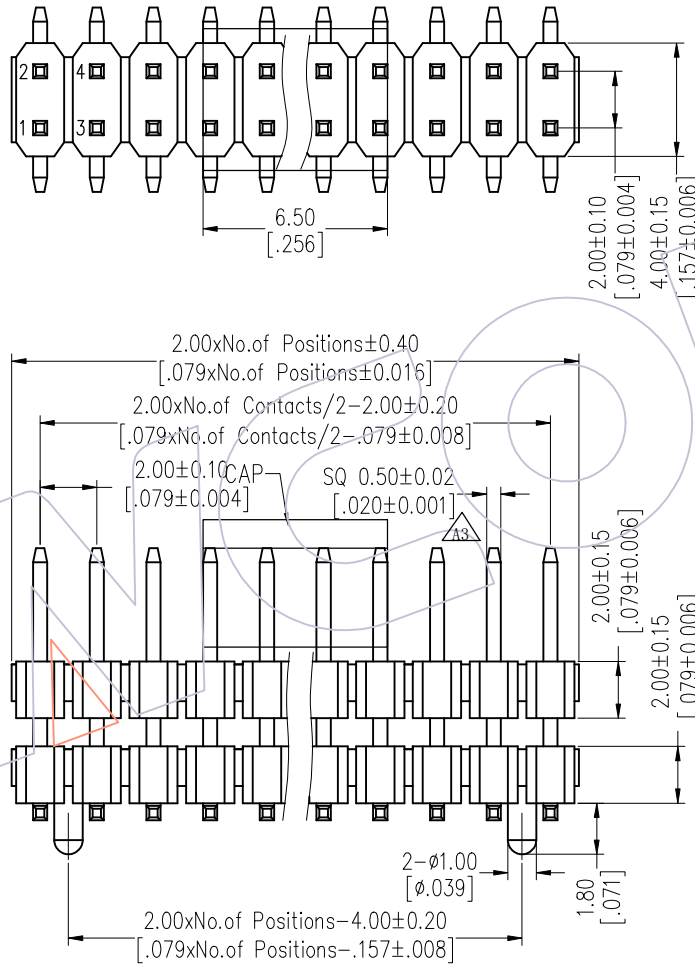

Recommended P.C.B Layout (Top Side)
 (PCB BOARD TOLERANCE ± 0.05)
 (PCB Thickness: T=1.60m)

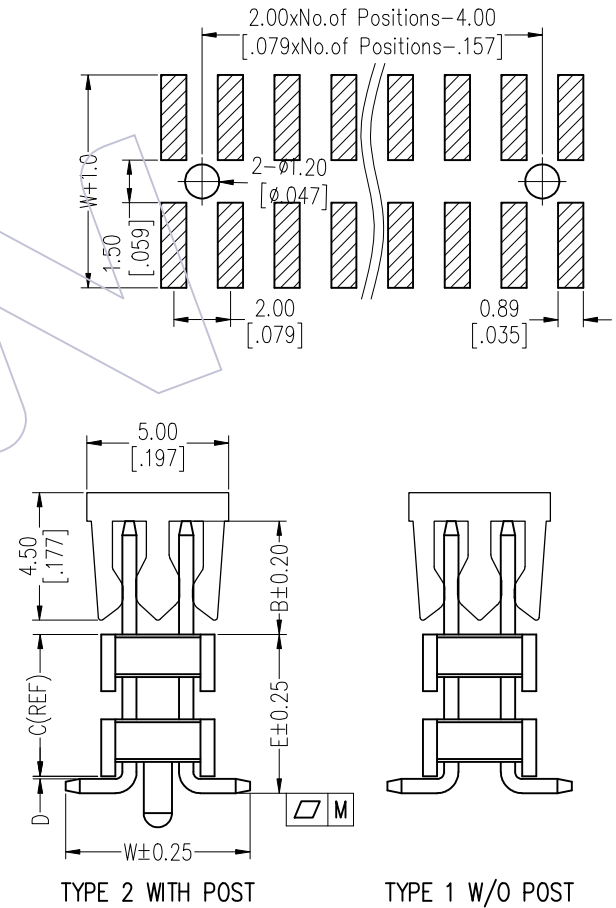

PIN(PerRow)	2-15P	16-25P	26-40P	$\triangle A2$
M	0.10	0.15	0.18	

A3	2025/08/07	Standardization Drawing	CP	OPERATION	DRAW	DATE	SCALE	Fit	PART NO.
A2	2023/02/02	Add Flatness	Du Ying	x.X ± 0.40	CP	2025/08/07	UNIT	mm	1220-22XXXXMXXCRXX $\triangle A1$
A1	2018/01/19	Modify P/N	Liu	x.XX ± 0.25	CHECK	DATE	SIZE	A4	TITLE:
A0	2012/04/26	NEW	William Chen	x.XXX ± 0.15	TANG	2025/08/07	SHEET	1/6	PH2.00 DUAL ROW DOUBLE PLASTIC SMT H=2.0
REV	DATE	MODIFICATION DESCRIPTION	CHANGE	Angle $\pm 3^\circ$	APPROVE	DATE	PROJ.	ϕ	Customer NO.
				DIM TOL	Steven Zhao	2025/08/07			

WCON
 Http: www.wcon.com

WCON-Dongguan
 Tel: +86 769 85358920
 Fax: +86 769 85358915
 E-mail: sales@wcon.com

WCON-Kunshan
 Tel: +86 512 57468408
 Fax: +86 512 57468468
 E-mail: salesks@wcon.com

HSF

Packing:

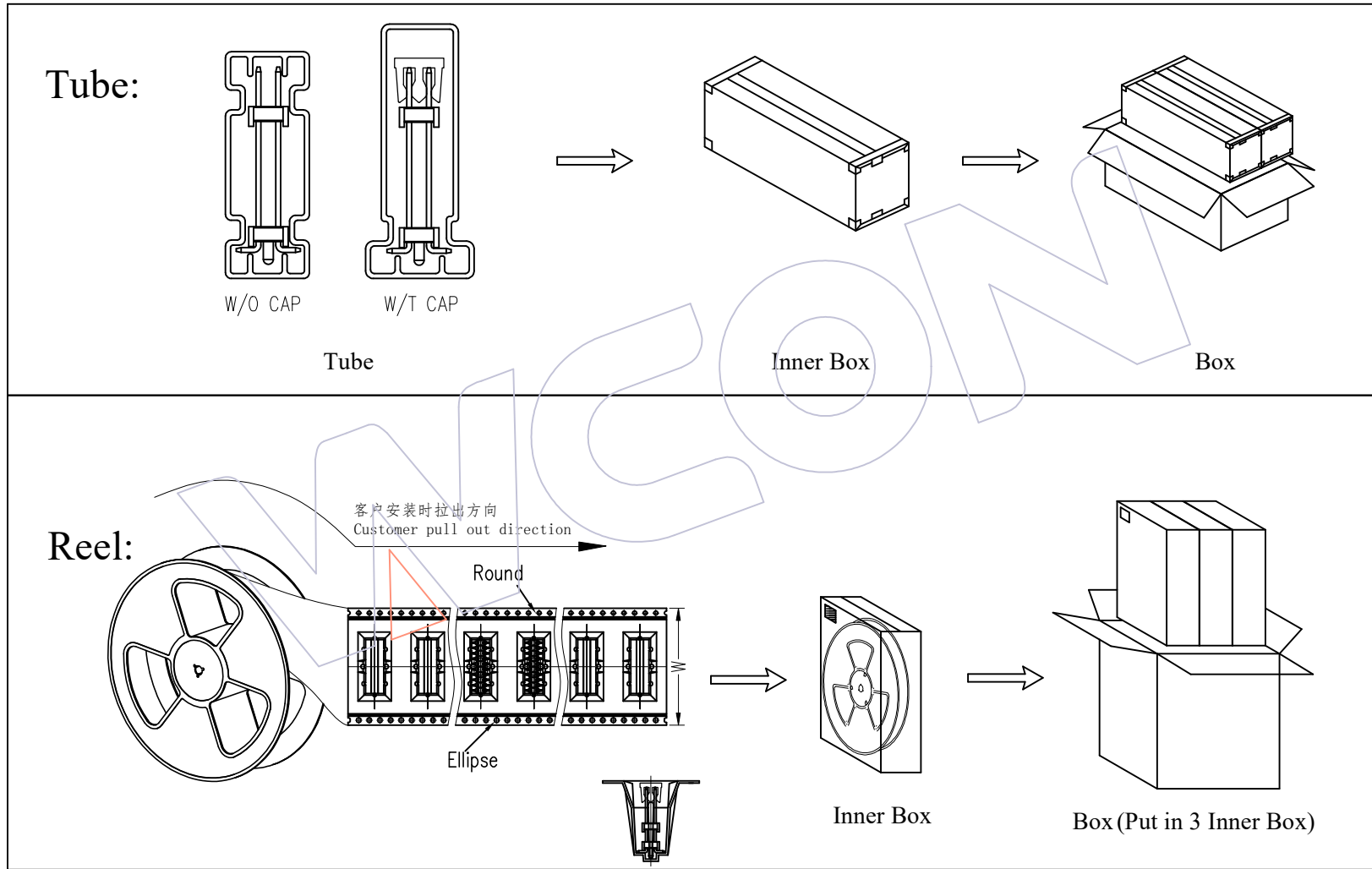

A3	2025/08/07	Standardization Drawing	CP	OPERATION	DRAW	DATE	SCALE	Fit	PART NO.
A2	2023/02/02	Add Flatness	Du Ying	X.X ±0.40	CP	2025/08/07	UNIT	mm	1220-22XXXXMXXXXCRXX
A1	2018/01/19	Modify P/N	Liu	X.XX ±0.25	CHECK	DATE	SIZE	A4	TITLE:
A0	2012/04/26	NEW	William Chen	X.XXX ±0.15	TANG	2025/08/07	SHEET	2/6	PH2.00 DUAL ROW DOUBLE PLASTIC SMT H=2.0
REV	DATE	MODIFICATION DESCRIPTION	CHANGE	Angle ± 3°	APPROVE	DATE	PROJ.		Customer NO.
				DIM TOL	Steven Zhao	2025/08/07			

WCON
Http: www.wcon.com

WCON-Dongguan WCON-Kunshan
Tel: +86 769 85358920 Tel: +86 512 57468408
Fax: +86 769 85358915 Fax: +86 512 57468468
E-mail: sales@wcon.com E-mail: salesks@wcon.com

HSF

Table

Item	L	E	C	D	W	B	Mating
Standard	11.8	7.4	6.8	0.10	4.5	2.5	2220T/2221/2228
	3.0					2227T/2228T/2245	
	3.5					2235/2240N/2243C	
	4.0					2240/2243/2245T/2263/2272	
	12.8	8.6	8.0			2.5	2220T/2221/2228
	3.0					2227T/2228T/2245	
	3.5					2235/2240N/2243C	
	4.0					2240/2243/2245T/2263/2272	
	13.3	9.4	8.8			2.5	2220T/2221/2228
	3.0					2227T/2228T/2245	
	3.5					2235/2240N/2243C	
	4.0					2240/2243/2245T/2263/2272	
	13.8	11.1	10.5			2.5	2220T/2221/2228
	3.0					2227T/2228T/2245	
	3.5					2235/2240N/2243C	
	4.0					2240/2243/2245T/2263/2272	
	14.2	12.4	11.8			2.5	2220T/2221/2228
	3.0					2227T/2228T/2245	
	3.5					2235/2240N/2243C	
	4.0					2240/2243/2245T/2263/2272	
14.6	14.2	13.6	2.5	2220T/2221/2228			
3.0			2227T/2228T/2245				
3.5			2235/2240N/2243C				
4.0			2240/2243/2245T/2263/2272				
15.0	Alternate						

Packaging Quantity Refers To The Following Table

W/O CAP				W/O CAP				W/T CAP				W/T CAP			
PINS /Row	Q'ty/Tube	Q'ty/Inner Box	Q'ty/Box	PINS /Row	Q'ty/Tube	Q'ty/Inner Box	Q'ty/Box	PINS /Row	Q'ty/Tube	Q'ty/Inner Box	Q'ty/Box	PINS /Row	Q'ty/Tube	Q'ty/Inner Box	Q'ty/Box
4	72	5,760	11,520	23	12	960	1,920	4	72	4,320	8,640	23	12	720	1,440
5	58	4,640	9,280	24	11	880	1,760	5	58	3,480	6,960	24	11	660	1,320
6	48	3,840	7,680	25	11	880	1,760	6	48	2,880	5,760	25	11	660	1,320
7	41	3,280	6,560	26	11	880	1,760	7	41	2,460	4,920	26	11	660	1,320
8	36	2,880	5,760	27	10	800	1,600	8	36	2,160	4,320	27	10	600	1,200
9	32	2,560	5,120	28	10	800	1,600	9	32	1,920	3,840	28	10	600	1,200
10	29	2,320	4,640	29	9	720	1,440	10	29	1,740	3,480	29	9	540	1,080
11	26	2,080	4,160	30	9	720	1,440	11	26	1,560	3,120	30	9	540	1,080
12	24	1,920	3,840	31	9	720	1,440	12	24	1,440	2,880	31	9	540	1,080
13	22	1,760	3,520	32	9	720	1,440	13	22	1,320	2,640	32	9	540	1,080
14	20	1,600	3,200	33	8	640	1,280	14	20	1,200	2,400	33	8	480	960
15	19	1,520	3,040	34	8	640	1,280	15	19	1,140	2,280	34	8	480	960
16	18	1,440	2,880	35	8	640	1,280	16	18	1,080	2,160	35	8	480	960
17	17	1,360	2,720	36	8	640	1,280	17	17	1,020	2,040	36	8	480	960
18	16	1,280	2,560	37	7	560	1,120	18	16	960	1,920	37	7	420	840
19	15	1,200	2,400	38	7	560	1,120	19	15	900	1,800	38	7	420	840
20	14	1,120	2,240	39	7	560	1,120	20	14	840	1,680	39	7	420	840
21	13	1,040	2,080	40	7	560	1,120	21	13	780	1,560	40	7	420	840
22	13	1,040	2,080					22	13	780	1,560				

A3	2025/08/07	Standardization Drawing	CP	OPERATION	DRAW	DATE	SCALE	Fit	PART NO.	 Http: www.wcon.com WCON-Dongguan Tel: +86 769 85358920 WCON-Kunshan Tel: +86 512 57468408 Fax: +86 769 85358915 Fax: +86 512 57468468 E-mail: sales@wcon.com E-mail: salesks@wcon.com
A2	2023/02/02	Add Flatness	Du Ying	x.X ±0.40	CP	2025/08/07	UNIT	mm	TITLE:	
A1	2018/01/19	Modify P/N	Liu	x.xx ±0.25	CHECK	DATE	SIZE	A4	PH2.00 DUAL ROW DOUBLE PLASTIC SMT H=2.0	
A0	2012/04/26	NEW	William Chen	x.xxx ±0.15	TANG	2025/08/07	SHEET	3/6	Customer NO.	
REV	DATE	MODIFICATION DESCRIPTION	CHANGE	Angle ± 3°	APPROVE	DATE	PROJ.			
				DIM TOL	Steven Zhao	2025/08/07				



Packaging Quantity Refers To The Following Table

E=7.4,B=2.5/3.0					E=7.4,B=3.5/4.0					E=8.6,B=2.5/3.0					E=8.6,B=3.5/4.0				
PINS /Row	W	Q'ty/Reel	Q'ty/Inner Box	Q'ty/Box	PINS /Row	W	Q'ty/Reel	Q'ty/Inner Box	Q'ty/Box	PINS /Row	W	Q'ty/Reel	Q'ty/Inner Box	Q'ty/Box	PINS /Row	W	Q'ty/Reel	Q'ty/Inner Box	Q'ty/Box
2	24	290	870	2,610	2	24	250	750	2,250	2	24	250	750	2,250	2	24	250	750	2,250
3	24	290	870	2,610	3	24	250	750	2,250	3	24	250	750	2,250	3	24	250	750	2,250
4	24	290	870	2,610	4	24	250	750	2,250	4	24	250	750	2,250	4	24	250	750	2,250
5	24	290	870	2,610	5	32	250	500	1,500	5	32	250	500	1,500	5	32	250	500	1,500
6	32	290	580	1,740	6	32	250	500	1,500	6	32	250	500	1,500	6	32	250	500	1,500
7	44	290	580	1,740	7	44	250	500	1,500	7	44	250	500	1,500	7	44	250	500	1,500
8	44	290	580	1,740	8	44	250	500	1,500	8	44	250	500	1,500	8	44	250	500	1,500
9	44	290	580	1,740	9	44	250	500	1,500	9	44	250	500	1,500	9	44	250	500	1,500
10	44	290	580	1,740	10	44	250	500	1,500	10	44	250	500	1,500	10	44	250	500	1,500
11	44	290	580	1,740	11	44	250	500	1,500	11	44	250	500	1,500	11	44	250	500	1,500
12	44	290	580	1,740	12	44	250	500	1,500	12	44	250	500	1,500	12	56	250	250	750
13	56	290	290	870	13	56	250	250	750	13	56	250	250	750	13	56	250	250	750
14	56	290	290	870	14	56	250	250	750	14	56	250	250	750	14	56	250	250	750
15	56	290	290	870	15	56	250	250	750	15	56	250	250	750	15	56	250	250	750
16	56	290	290	870	16	56	250	250	750	16	56	250	250	750	16	56	250	250	750
17	56	290	290	870	17	56	250	250	750	17	56	250	250	750	17	56	250	250	750
18	56	290	290	870	18	56	250	250	750	18	56	250	250	750	18	72	250	250	750
19	72	290	290	870	19	72	250	250	750	19	72	250	250	750	19	72	250	250	750
20	72	290	290	870	20	72	250	250	750	20	72	250	250	750	20	72	250	250	750
21	72	290	290	870	21	72	250	250	750	21	72	250	250	750	21	72	250	250	750
22	72	290	290	870	22	72	250	250	750	22	72	250	250	750	22	72	250	250	750
23	72	290	290	870	23	72	250	250	750	23	72	250	250	750	23	72	250	250	750
24	72	290	290	870	24	72	250	250	750	24	72	250	250	750	24	72	250	250	750
25	72	290	290	870	25	72	250	250	750	25	72	250	250	750	25	72	250	250	750
26	72	290	290	870	26	72	250	250	750	26	72	250	250	750	26	88	250	250	750
27	88	290	290	870	27	88	250	250	750	27	88	250	250	750	27	88	250	250	750
28	88	290	290	870	28	88	250	250	750	28	88	250	250	750	28	88	250	250	750
29	88	290	290	870	29	88	250	250	750	29	88	250	250	750	29	88	250	250	750
30	88	290	290	870	30	88	250	250	750	30	88	250	250	750	30	88	250	250	750

A3	2025/08/07	Standardization Drawing	CP	OPERATION	DRAW	DATE	SCALE	Fit	PART NO. 1220-22XXXXMXXCRXX
A2	2023/02/02	Add Flatness	Du Ying	x.X ±0.40	CP	2025/08/07	UNIT	mm	TITLE: PH2.00 DUAL ROW DOUBLE PLASTIC SMT H=2.0
A1	2018/01/19	Modify P/N	Liu	x.XX ±0.25	CHECK	2025/08/07	SIZE	A4	
A0	2012/04/26	NEW	William Chen	x.XXX ±0.15	TANG		SHEET	4/6	Customer NO.
REV	DATE	MODIFICATION DESCRIPTION	CHANGE	Angle ± 3'	APPROVE Steven Zhao	DATE 2025/08/07	PROJ.		



WCON-Dongguan Tel: +86 769 85358920 Fax: +86 769 85358915 E-mail: sales@wcon.com	WCON-Kunshan Tel: +86 512 57468408 Fax: +86 512 57468468 E-mail: salesks@wcon.com
---	--

HSF

Packaging Quantity Refers To The Following Table

E=9.4,B=2.5/3.0					E=9.4,B=3.5/4.0					E=11.1,B=2.5/3.0					E=11.1,B=3.5/4.0				
PINS /Row	W	Q'ty/Reel	Q'ty/Inner Box	Q'ty/Box	PINS /Row	W	Q'ty/Reel	Q'ty/Inner Box	Q'ty/Box	PINS /Row	W	Q'ty/Reel	Q'ty/Inner Box	Q'ty/Box	PINS /Row	W	Q'ty/Reel	Q'ty/Inner Box	Q'ty/Box
2	24	250	750	2,250	2	24	170	510	1,530	2	24	170	510	1,530	2	24	160	480	1,440
3	24	250	750	2,250	3	24	170	510	1,530	3	24	170	510	1,530	3	24	160	480	1,440
4	24	250	750	2,250	4	24	170	510	1,530	4	32	170	340	1,020	4	32	160	320	960
5	32	250	500	1,500	5	32	170	340	1,020	5	32	170	340	1,020	5	32	160	320	960
6	32	250	500	1,500	6	32	170	340	1,020	6	32	170	340	1,020	6	44	160	320	960
7	44	250	500	1,500	7	44	170	340	1,020	7	44	170	340	1,020	7	44	160	320	960
8	44	250	500	1,500	8	44	170	340	1,020	8	44	170	340	1,020	8	44	160	320	960
9	44	250	500	1,500	9	44	170	340	1,020	9	44	170	340	1,020	9	44	160	320	960
10	44	250	500	1,500	10	44	170	340	1,020	10	44	170	340	1,020	10	44	160	320	960
11	44	250	500	1,500	11	44	170	340	1,020	11	44	170	340	1,020	11	56	160	160	480
12	56	250	250	750	12	56	170	170	510	12	56	170	170	510	12	56	160	160	480
13	56	250	250	750	13	56	170	170	510	13	56	170	170	510	13	56	160	160	480
14	56	250	250	750	14	56	170	170	510	14	56	170	170	510	14	56	160	160	480
15	56	250	250	750	15	56	170	170	510	15	56	170	170	510	15	56	160	160	480
16	56	250	250	750	16	56	170	170	510	16	56	170	170	510	16	56	160	160	480
17	56	250	250	750	17	56	170	170	510	17	56	170	170	510	17	72	160	160	480
18	72	250	250	750	18	72	170	170	510	18	72	170	170	510	18	72	160	160	480
19	72	250	250	750	19	72	170	170	510	19	72	170	170	510	19	72	160	160	480
20	72	250	250	750	20	72	170	170	510	20	72	170	170	510	20	72	160	160	480
21	72	250	250	750	21	72	170	170	510	21	72	170	170	510	21	72	160	160	480
22	72	250	250	750	22	72	170	170	510	22	72	170	170	510	22	72	160	160	480
23	72	250	250	750	23	72	170	170	510	23	72	170	170	510	23	72	160	160	480
24	72	250	250	750	24	72	170	170	510	24	72	170	170	510	24	72	160	160	480
25	72	250	250	750	25	72	170	170	510	25	72	170	170	510	25	88	160	160	480
26	88	250	250	750	26	88	170	170	510	26	88	170	170	510	26	88	160	160	480
27	88	250	250	750	27	88	170	170	510	27	88	170	170	510	27	88	160	160	480
28	88	250	250	750	28	88	170	170	510	28	88	170	170	510	28	88	160	160	480
29	88	250	250	750	29	88	170	170	510	29	88	170	170	510	29	88	160	160	480
30	88	250	250	750	30	88	170	170	510	30	88	170	170	510	30	88	160	160	480

A3	2025/08/07	Standardization Drawing	CP	OPERATION	DRAW	DATE	SCALE	Fit	PART NO.	 Http: www.wcon.com
A2	2023/02/02	Add Flatness	Du Ying	x.X ±0.40	CP	2025/08/07	UNIT	mm	1220-22XXXXMXXCRXX	
A1	2018/01/19	Modify P/N	Liu	x.XX ±0.25	CHECK	DATE	SIZE	A4	TITLE:	
A0	2012/04/26	NEW	William Chen	x.XXX ±0.15	TANG	2025/08/07	SHEET	5/6	PH2.00 DUAL ROW DOUBLE PLASTIC SMT H=2.0	
REV	DATE	MODIFICATION DESCRIPTION	CHANGE	Angle ± 3°	APPROVE	DATE	PROJ.	Customer NO.	WCON-Dongguan Tel: +86 769 85358920 Fax: +86 769 85358915 E-mail: sales@wcon.com	
				DIM TOL	Steven Zhao	2025/08/07			WCON-Kunshan Tel: +86 512 57468408 Fax: +86 512 57468468 E-mail: salesks@wcon.com	

HSF

Packaging Quantity Refers To The Following Table

E=12.4,B=2.5/3.0					E=12.4,B=3.5/4.0					E=14.2,B=2.5/3.0					E=14.2,B=3.5/4.0				
PINS /Row	W	Q'ty/Reel	Q'ty/Inner Box	Q'ty/Box	PINS /Row	W	Q'ty/Reel	Q'ty/Inner Box	Q'ty/Box	PINS /Row	W	Q'ty/Reel	Q'ty/Inner Box	Q'ty/Box	PINS /Row	W	Q'ty/Reel	Q'ty/Inner Box	Q'ty/Box
2	24	170	510	1,530	2	24	130	390	1,170	2	24	130	390	1,170	2	24	110	330	990
3	24	170	510	1,530	3	24	130	390	1,170	3	24	130	390	1,170	3	32	110	220	660
4	32	170	340	1,020	4	32	130	260	780	4	32	130	260	780	4	32	110	220	660
5	32	170	340	1,020	5	32	130	260	780	5	32	130	260	780	5	32	110	220	660
6	44	170	340	1,020	6	44	130	260	780	6	44	130	260	780	6	44	110	220	660
7	44	170	340	1,020	7	44	130	260	780	7	44	130	260	780	7	44	110	220	660
8	44	170	340	1,020	8	44	130	260	780	8	44	130	260	780	8	44	110	220	660
9	44	170	340	1,020	9	44	130	260	780	9	44	130	260	780	9	44	110	220	660
10	44	170	340	1,020	10	44	130	260	780	10	44	130	260	780	10	56	110	110	330
11	56	170	170	510	11	56	130	130	390	11	56	130	130	390	11	56	110	110	330
12	56	170	170	510	12	56	130	130	390	12	56	130	130	390	12	56	110	110	330
13	56	170	170	510	13	56	130	130	390	13	56	130	130	390	13	56	110	110	330
14	56	170	170	510	14	56	130	130	390	14	56	130	130	390	14	56	110	110	330
15	56	170	170	510	15	56	130	130	390	15	56	130	130	390	15	56	110	110	330
16	56	170	170	510	16	56	130	130	390	16	56	130	130	390	16	72	110	110	330
17	72	170	170	510	17	72	130	130	390	17	72	130	130	390	17	72	110	110	330
18	72	170	170	510	18	72	130	130	390	18	72	130	130	390	18	72	110	110	330
19	72	170	170	510	19	72	130	130	390	19	72	130	130	390	19	72	110	110	330
20	72	170	170	510	20	72	130	130	390	20	72	130	130	390	20	72	110	110	330
21	72	170	170	510	21	72	130	130	390	21	72	130	130	390	21	72	110	110	330
22	72	170	170	510	22	72	130	130	390	22	72	130	130	390	22	72	110	110	330
23	72	170	170	510	23	72	130	130	390	23	72	130	130	390	23	72	110	110	330
24	72	170	170	510	24	72	130	130	390	24	72	130	130	390	24	88	110	110	330
25	88	170	170	510	25	88	130	130	390	25	88	130	130	390	25	88	110	110	330
26	88	170	170	510	26	88	130	130	390	26	88	130	130	390	26	88	110	110	330
27	88	170	170	510	27	88	130	130	390	27	88	130	130	390	27	88	110	110	330
28	88	170	170	510	28	88	130	130	390	28	88	130	130	390	28	88	110	110	330
29	88	170	170	510	29	88	130	130	390	29	88	130	130	390	29	88	110	110	330
30	88	170	170	510	30	88	130	130	390	30	88	130	130	390	30	88	110	110	330

A3	2025/08/07	Standardization Drawing	CP	OPERATION	DRAW	DATE	SCALE	Fit	PART NO.	 Http: www.wcon.com	
A2	2023/02/02	Add Flatness	Du Ying	x.X ±0.40	CP	2025/08/07	UNIT	mm	1220-22XXXXMXXCRXX		
A1	2018/01/19	Modify P/N	Liu	x.XX ±0.25	CHECK	DATE	SIZE	A4	TITLE:		
A0	2012/04/26	NEW	William Chen	x.XXX ±0.15	TANG	2025/08/07	SHEET	6/6	PH2.00 DUAL ROW DOUBLE PLASTIC SMT H=2.0		
REV	DATE	MODIFICATION DESCRIPTION	CHANGE	Angle ± 3°	APPROVE	DATE	PROJ.	Customer NO.		WCON-Dongguan Tel: +86 769 85358920 Fax: +86 769 85358915 E-mail: sales@wcon.com	WCON-Kunshan Tel: +86 512 57468408 Fax: +86 512 57468468 E-mail: salesks@wcon.com