

HSF

NOTES:

Rated Current:5.0AMP.(20°C,1*2P-1*15P)
 3.0AMP.(20°C,1*16P-1*40P) $\triangle A3$
 Contact Resistance:20m Ω Max.
 Withstand Voltage:1000V AC/DC
 Insulation Resistance:1000M Ω Min.
 Operation Temperature:-40°C to +125°C(Gold Plating)
 -40°C to +105°C(Tin Plating) $\triangle A3$
 Contact Material:Copper Alloy
 Contact Plating:Au or Sn Over 30u" Min Ni $\triangle A3$
 Insulator Material:PA9T+G.F UL94V-0 BK $\triangle A3$

Ordering Information

1117-1 1 XX XX M XXX C R XX $\triangle A1$

Plastic Layer
 Plastic Row
 No. of Pins
 Per Row:02-40
 Contact Plating
 G0=Gold Flash
 G3=10u"Au, BG3=8u"PdNi+2u"Au
 G4=15u"Au, BG4=13u"PdNi+2u"Au
 G5=30u"Au, BG5=28u"PdNi+2u"Au
 S0=Gold Flash/Tin $\triangle A3$
 S3=10u"Au/Sn, P3=8u"PdNi+2u"Au/Sn
 S4=15u"Au/Sn, P4=13u"PdNi+2u"Au/Sn
 S5=30u"Au/Sn, P5=28u"PdNi+2u"Au/Sn
 SN=Bright Tin
 SM=Matte Tin

Series No.
 01-99
 Packing
 T=Tube
 P=Tube+CAP
 R=Tape & Reel+CAP
 Insulator Material
 C=PA9T(Standard)
 Pin Length
 L(See Table)
 Type:
 M=SMT

Item	Pin Length	W	D	E	B	Mating
Standard	8.0	4.83	0.6	2.94	3.5	2135/2150T/2157
	8.5				4.0	2145/2150
	9.5				5.0	2168T/2171T
	10.5				5.84	2171/2185X
Alternate						

PIN(PerRow)	2-15P	16-25P	26-40P
M	0.10	0.15	0.20 $\triangle A2$

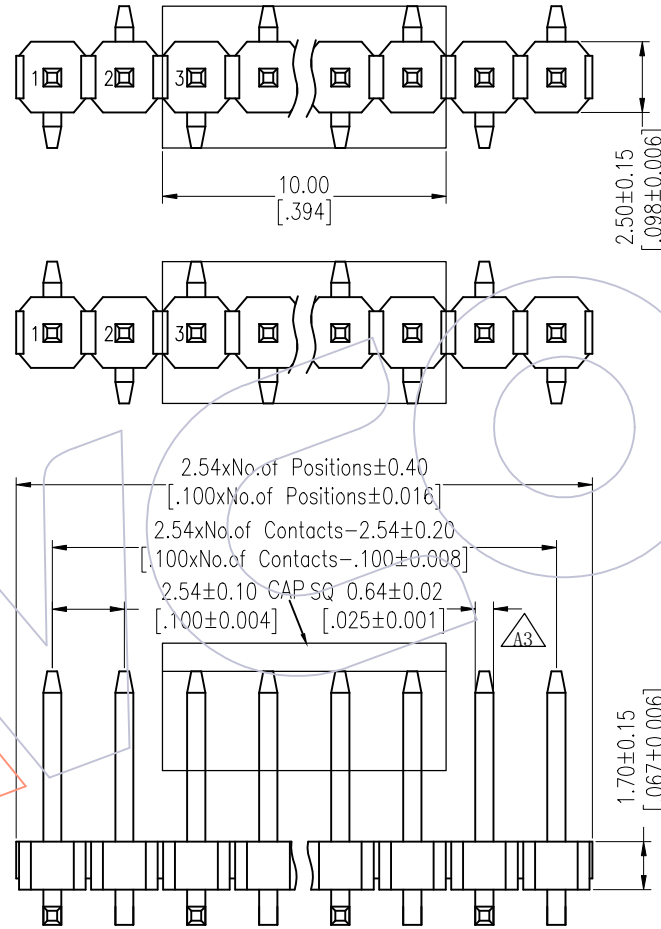

Recommended P.C.B Layout (Top Side)
 (PCB BOARD TOLERANCE±0.05)
 (PCB Thickness:T=1.60m)

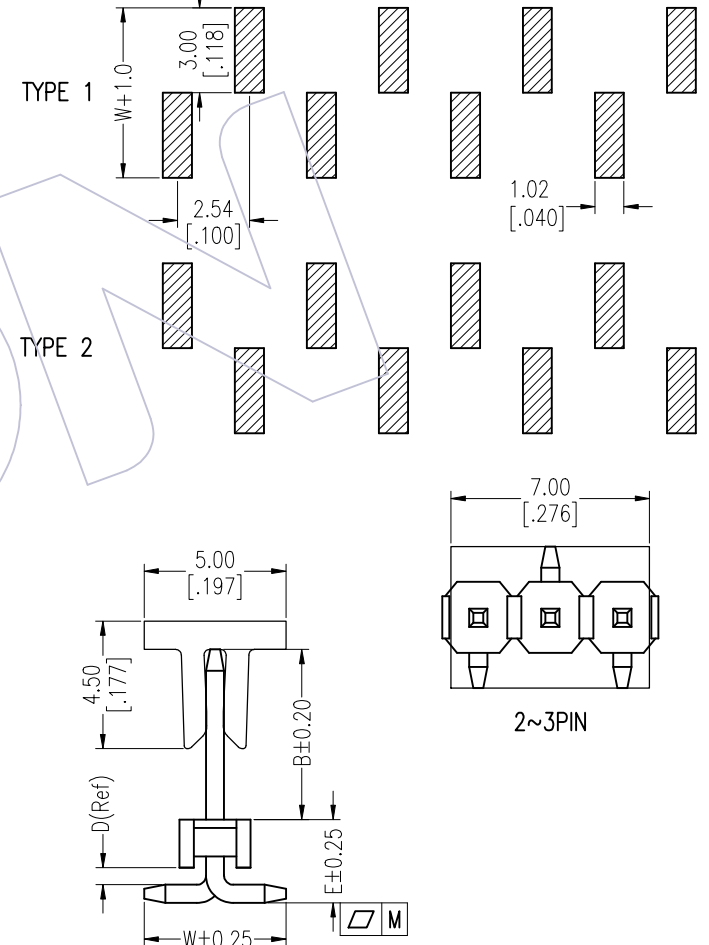

REV	DATE	MODIFICATION DESCRIPTION	CHANGE	OPERATION	DATE	SCALE	Fit	PART NO.
A3	2025/03/01	Standardization Drawing	CP	OPERATION	DATE	SCALE	Fit	PART NO.
A2	2023/02/03	Add Flatness	DuYing	x.X ±0.40	2025/03/01	UNIT	mm	1117-11XXXXMXXCRXX
A1	2018/01/22	Modify P/N	Ruipeng	x.XX ±0.25	DATE	SIZE	A4	TITLE:
A0	2012/05/04	NEW	William Chen	x.XXX ±0.15	2025/03/01	SHEET	1/4	PH2.54 SINGLE ROW SMT
				Angle ± 3'	DATE	PROJ.		H=1.7
				DIM TOL	2025/03/01			Customer NO.

WCON
 Http: www.wcon.com

WCON-Dongguan
 Tel: +86 769 85358920
 Fax: +86 769 85358915
 E-mail: sales@wcon.com

WCON-Kunshan
 Tel: +86 512 57468408
 Fax: +86 512 57468468
 E-mail: sales@wcon.com

HSF

Packing:

Tube:

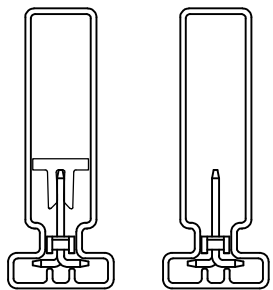

W/T CAP W/O CAP

Tube

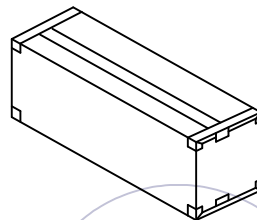
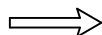

Inner Box

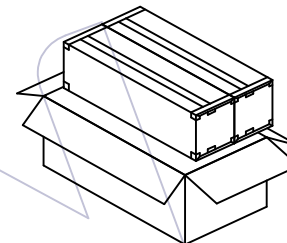
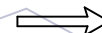

Box

Reel:

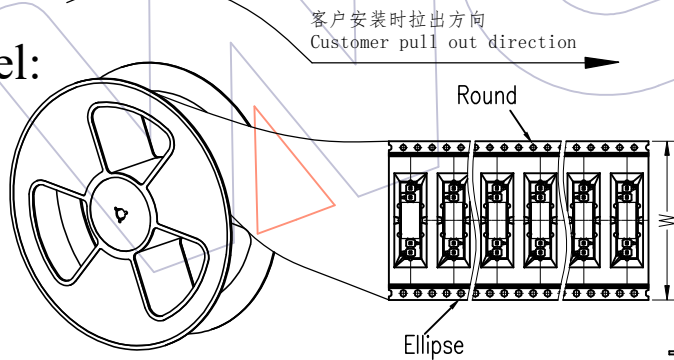

客户安装时拉出方向
Customer pull out direction

Round

Ellipse

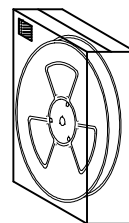

Inner Box

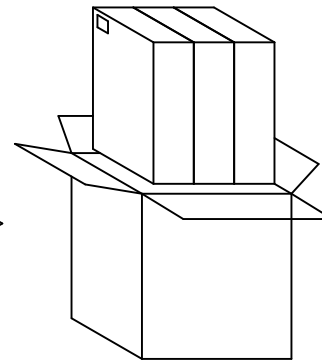
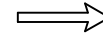

Box (Put in 3 Inner Box)

A3	2025/03/01	Standardization Drawing	CP	OPERATION	DRAW	DATE	SCALE	Fit	PART NO.
A2	2023/02/03	Add Flatness	DuYing	x.X ±0.40	CP	2025/03/01	UNIT	mm	1117-11XXXXMXXCRXX
A1	2018/01/22	Modify P/N	Ruipeng	x.XX ±0.25	CHECK	DATE	SIZE	A4	TITLE:
A0	2012/05/04	NEW	William Chen	x.XXX ±0.15	TANG	2025/03/01	SHEET	2/4	PH2.54 SINGLE ROW SMT
REV	DATE	MODIFICATION DESCRIPTION	CHANGE	Angle ± 3'	APPROVE	DATE	PROJ.	⊕	H=1.7
				DIM TOL	Steven Zhao	2025/03/01			Customer NO.

WCON
[Http: www.wcon.com](http://www.wcon.com)

WCON-Dongguan WCON-Kunshan
 Tel: +86 769 85358920 Tel: +86 512 57468408
 Fax: +86 769 85358915 Fax: +86 512 57468468
 E-mail: sales@wcon.com E-mail: salesks@wcon.com

HSF

Packaging Quantity Refers To The Following Table

B=3.5

PINS	W	Q' ty/Reel	Q' ty/Inner Box	Q' ty/Box
2	24	650	1,950	5,850
3	24	650	1,950	5,850
4	24	650	1,950	5,850
5	24	650	1,950	5,850
6	32	650	1,300	3,900
7	44	650	1,300	3,900
8	44	650	1,300	3,900
9	44	650	1,300	3,900
10	44	650	1,300	3,900
11	44	650	1,300	3,900
12	56	650	650	1,950
13	56	650	650	1,950
14	56	650	650	1,950
15	56	650	650	1,950
16	56	650	650	1,950
17	72	650	650	1,950
18	72	650	650	1,950
19	72	650	650	1,950
20	72	650	650	1,950
21	72	650	650	1,950
22	72	650	650	1,950
23	88	650	650	1,950
24	88	650	650	1,950
25	88	650	650	1,950
26	88	650	650	1,950
27	88	650	650	1,950

B=4.0

PINS	W	Q' ty/Reel	Q' ty/Inner Box	Q' ty/Box
2	24	600	1,800	5,400
3	24	600	1,800	5,400
4	24	600	1,800	5,400
5	24	600	1,800	5,400
6	32	600	1,200	3,600
7	44	600	1,200	3,600
8	44	600	1,200	3,600
9	44	600	1,200	3,600
10	44	600	1,200	3,600
11	44	600	1,200	3,600
12	56	600	600	1,800
13	56	600	600	1,800
14	56	600	600	1,800
15	56	600	600	1,800
16	56	600	600	1,800
17	72	600	600	1,800
18	72	600	600	1,800
19	72	600	600	1,800
20	72	600	600	1,800
21	72	600	600	1,800
22	72	600	600	1,800
23	88	600	600	1,800
24	88	600	600	1,800
25	88	600	600	1,800
26	88	600	600	1,800
27	88	600	600	1,800

PINS	Q' ty/Tube	Q' ty/Inner Box	Q' ty/Box
4	54	4,320	8,640
5	44	3,520	7,040
6	37	2,960	5,920
7	31	2,480	4,960
8	27	2,160	4,320
9	24	1,920	3,840
10	22	1,760	3,520
11	20	1,600	3,200
12	18	1,440	2,880
13	17	1,360	2,720
14	16	1,280	2,560
15	15	1,200	2,400
16	14	1,120	2,240
17	13	1,040	2,080
18	12	960	1,920
19	11	880	1,760
20	11	880	1,760
21	10	800	1,600
22	10	800	1,600

PINS	Q' ty/Tube	Q' ty/Inner Box	Q' ty/Box
23	9	720	1,440
24	9	720	1,440
25	9	720	1,440
26	8	640	1,280
27	8	640	1,280
28	8	640	1,280
29	7	560	1,120
30	7	560	1,120
31	7	560	1,120
32	7	560	1,120
33	6	480	960
34	6	480	960
35	6	480	960
36	6	480	960
37	6	480	960
38	5	400	800
39	5	400	800
40	5	400	800

REV	DATE	MODIFICATION DESCRIPTION	CHANGE	DIM	TOL	APPROVE	DATE	PROJ.	SCALE	Fit	PART NO.	TITLE:	Customer NO.
A3	2025/03/01	Standardization Drawing	CP			OPERATION	DATE				1117-11XXXXMXXCRXX		
A2	2023/02/03	Add Flatness	DuYing	x.X	±0.40	CHECK	2025/03/01		UNIT	mm			
A1	2018/01/22	Modify P/N	Ruipeng	x.xx	±0.25	TANG	2025/03/01		SIZE	A4		PH2.54 SINGLE ROW SMT	
A0	2012/05/04	NEW	William Chen	x.xxx	±0.15				SHEET	3/4		H=1.7	
				Angle	± 3'	STEVEN ZHAO	2025/03/01						

WCON
[Http: www.wcon.com](http://www.wcon.com)

WCON-Dongguan
 Tel: +86 769 85358920
 Fax: +86 769 85358915
 E-mail: sales@wcon.com

WCON-Kunshan
 Tel: +86 512 57468408
 Fax: +86 512 57468468
 E-mail: salesks@wcon.com

HSF

Packaging Quantity Refers To The Following Table

B=5.0

PINS	W	Q' ty/Reel	Q' ty/Inner Box	Q' ty/Box
2	24	550	1,650	4,950
3	24	550	1,650	4,950
4	24	550	1,650	4,950
5	32	550	1,100	3,300
6	32	550	1,100	3,300
7	44	550	1,100	3,300
8	44	550	1,100	3,300
9	44	550	1,100	3,300
10	44	550	1,100	3,300
11	44	550	1,100	3,300
12	56	550	550	1,650
13	56	550	550	1,650
14	56	550	550	1,650
15	56	550	550	1,650
16	72	550	550	1,650
17	72	550	550	1,650
18	72	550	550	1,650
19	72	550	550	1,650
20	72	550	550	1,650
21	72	550	550	1,650
22	72	550	550	1,650
23	88	550	550	1,650
24	88	550	550	1,650
25	88	550	550	1,650
26	88	550	550	1,650
27	88	550	550	1,650

B=5.84

PINS	W	Q' ty/Reel	Q' ty/Inner Box	Q' ty/Box
2	24	500	1,500	4,500
3	24	500	1,500	4,500
4	24	500	1,500	4,500
5	32	500	1,000	3,000
6	32	500	1,000	3,000
7	44	500	1,000	3,000
8	44	500	1,000	3,000
9	44	500	1,000	3,000
10	44	500	1,000	3,000
11	56	500	500	1,500
12	56	500	500	1,500
13	56	500	500	1,500
14	56	500	500	1,500
15	56	500	500	1,500
16	72	500	500	1,500
17	72	500	500	1,500
18	72	500	500	1,500
19	72	500	500	1,500
20	72	500	500	1,500
21	72	500	500	1,500
22	88	500	500	1,500
23	88	500	500	1,500
24	88	500	500	1,500
25	88	500	500	1,500
26	88	500	500	1,500
27	88	500	500	1,500

A3	2025/03/01	Standardization Drawing	CP	OPERATION	DRAW	DATE	SCALE	Fit	PART NO.
A2	2023/02/03	Add Flatness	DuYing	x.X ±0.40	CP	2025/03/01	UNIT	mm	1117-11XXXXMXXCRXX
A1	2018/01/22	Modify P/N	Ruipeng	x.xx ±0.25	CHECK	DATE	SIZE	A4	TITLE:
A0	2012/05/04	NEW	William Chen	x.xxx ±0.15	TANG	2025/03/01	SHEET	4/4	PH2.54 SINGLE ROW SMT
REV	DATE	MODIFICATION DESCRIPTION	CHANGE	Angle ± 3'	APPROVE	DATE	PROJ.	Customer NO.	H=1.7
				DIM TOL	Steven Zhao	2025/03/01	⌀		

WCON
[Http: www.wcon.com](http://www.wcon.com)

WCON-Dongguan
 Tel: +86 769 85358920
 Fax: +86 769 85358915
 E-mail: sales@wcon.com

WCON-Kunshan
 Tel: +86 512 57468408
 Fax: +86 512 57468468
 E-mail: salesks@wcon.com