

# HSF

NOTES:

Rated Current: 1.5AMP.(20°C, 2\*2P-2\*15P)  
 1.0AMP.(20°C, 2\*16P-2\*50P)

Contact Resistance: 20mΩ Max.  
 Withstand Voltage: 500V AC/DC  
 Insulation Resistance: 1000MΩ Min.  
 Operation Temperature: -40°C to +125°C(Gold Plating)

Contact Material: Copper Alloy  
 Contact Plating: Au Over 30u" Min Ni  
 Insulator Material: PA9T+G.F UL94V-0 BK

Recommended P.C.B Layout(Top Side)  
 (PCB BOARD TOLERANCE ±0.05)  
 (PCB Thickness: T=1.60mm)

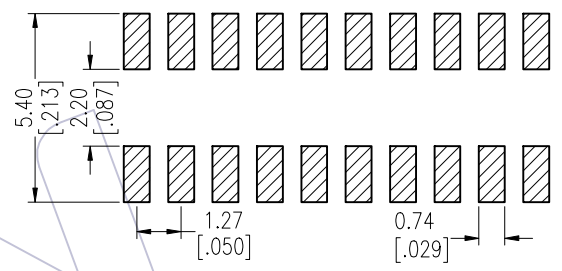
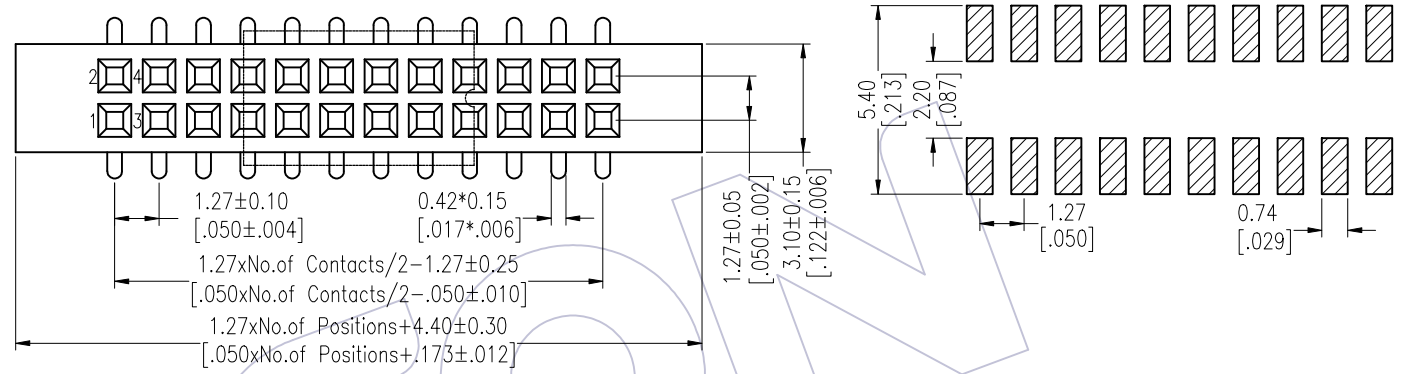

## Ordering Information

2334- 2 XX M XX C U N X 4

Plastic Row  
 No. of Pins Per Row: 02-50  
 Welding Type: M=SMT

Series No. 4=Long Type  
 Packing: T=Tube P=Tube+CAP R=Tape&Reel+CAP  
 Logo N=W/O Logo  
 Contact Type U=U Type  
 Insulator Material C=PA9T

Contact Plating  
 G0=Gold Flash  
 G3=10u"Au, BG3=8u"PdNi+2u"Au  
 G4=15u"Au, BG4=13u"PdNi+2u"Au  
 G5=30u"Au, BG5=28u"PdNi+2u"Au

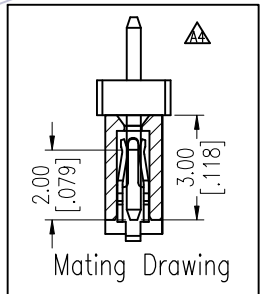
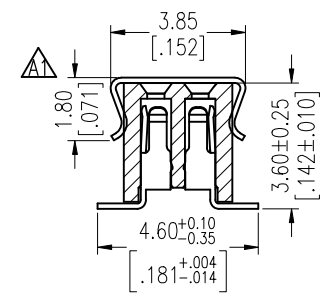
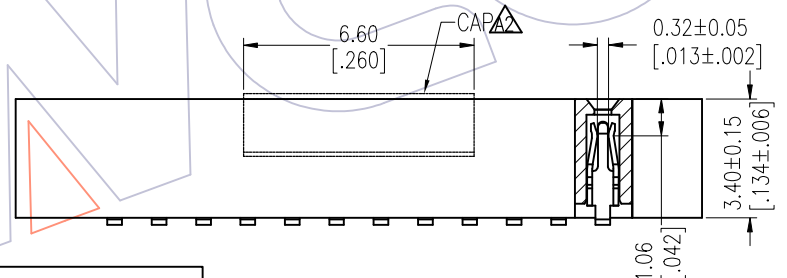

Item	Pitch	Mating	DIM.B
Standard	1.27	1310/1315/1320/3130	3.00
Alternate			

Pin(Per Row)	2-15P	16-30P	31-50P
M	0.10	0.15	0.18

REV	DATE	MODIFICATION DESCRIPTION	CHANGE	DIM	TOL	APPROVE	DATE	PROJ.	SCALE	FIT	PART NO.	TITLE:
A4	2026/01/15	Standardization Drawing	BAO	OPERATION		DRAW	DATE				2334-2XXMXXCUNX4	180°SMT LONG BODY H=3.40
A3	2023/02/03	ADD Flatness	XSR	x.x	±0.40	BAO	2026/01/15		UNIT	mm		
A2	2014/12/30	Modify CAP	-----	x.xx	±0.25	CHECK	DATE		SIZE	A4		
A0	2012/07/06	NEW	-----	x.xxx	±0.15	TANG	2026/01/15		SHEET	1/3		
				Angle	± 3'	APPROVE	DATE				Customer NO.	
						Steven Zhao	2026/01/15					

**WCON**  
 Http: www.wcon.com

WCON-Dongguan  
 Tel: +86 769 85358920  
 Fax: +86 769 85358915  
 E-mail: sales@wcon.com

WCON-Kunshan  
 Tel: +86 512 57468408  
 Fax: +86 512 57468468  
 E-mail: salesks@wcon.com

# HSF Packing:



## Tube:

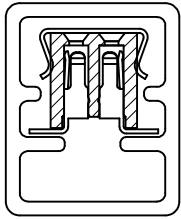

W/T CAP

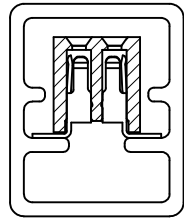

W/O CAP

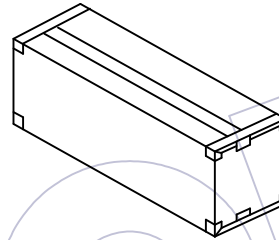
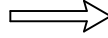

Inner Box

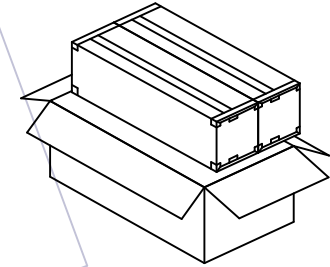

Box

## Reel:

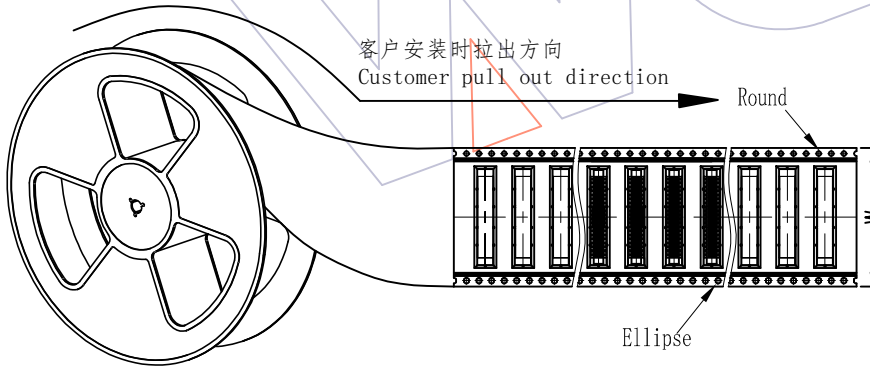

客户安装时拉出方向  
Customer pull out direction

Round

Ellipse

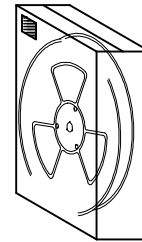
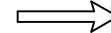

Inner Box

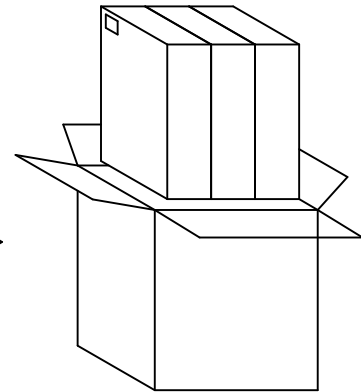
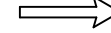

Box (Put in 3 Inner Box)

A4	2026/01/15	Standardization Drawing	BAO	OPERATION	DRAW	DATE	SCALE	FIT	PART NO.
A3	2023/02/03	ADD Flatness	XSR	x.X ±0.40	BAO	2026/01/15	UNIT	mm	2334-2XXMXXCUNX4
A2	2014/12/30	Modify CAP	-----	x.XX ±0.25	CHECK	DATE	SIZE	A4	TITLE:
A0	2012/07/06	NEW	-----	x.XXX ±0.15	TANG	2026/01/15	SHEET	2/3	1.27mm Female Header DUAL ROW 180°SMT LONG BODY H=3.40
REV	DATE	MODIFICATION DESCRIPTION	CHANGE	Angle ± 3'	APPROVE	DATE	PROJ.	Customer NO.	
				DIM TOL	Steven Zhao	2026/01/15			

**WCON**

Http: www.wcon.com

WCON-Dongguan  
Tel: +86 769 85358920  
Fax: +86 769 85358915  
E-mail: sales@wcon.com

WCON-Kunshan  
Tel: +86 512 57468408  
Fax: +86 512 57468468  
E-mail: salesks@wcon.com

# HSF

## Packaging Quantity Refers To The Following Table

PINS /Row	Q' ty/Tube	Q' ty/Inner Box	Q' ty/Box	PINS /Row	Q' ty/Tube	Q' ty/Inner Box	Q' ty/Box	PINS /Row	W	Q' ty/Reel	Q' ty/Inner Box	Q' ty/Box	PINS /Row	W	Q' ty/Reel	Q' ty/Inner Box	Q' ty/Box
2	500/Tray	/	24,000	27	14	4,480	8,960	2	16	1,250	5,000	15,000	27	56	1,250	1,250	3,750
3	70	22,400	44,800	28	14	4,480	8,960	3	24	1,250	3,750	11,250	28	56	1,250	1,250	3,750
4	61	19,520	39,040	29	14	4,480	8,960	4	24	1,250	3,750	11,250	29	56	1,250	1,250	3,750
5	53	16,960	33,920	30	13	4,160	8,320	5	24	1,250	3,750	11,250	30	56	1,250	1,250	3,750
6	43	13,760	27,520	31	13	4,160	8,320	6	24	1,250	3,750	11,250	31	56	1,250	1,250	3,750
7	43	13,760	27,520	32	12	3,840	7,680	7	24	1,250	3,750	11,250	32	72	1,250	1,250	3,750
8	39	12,480	24,960	33	12	3,840	7,680	8	24	1,250	3,750	11,250	33	72	1,250	1,250	3,750
9	36	11,520	23,040	34	12	3,840	7,680	9	24	1,250	3,750	11,250	34	72	1,250	1,250	3,750
10	33	10,560	21,120	35	11	3,520	7,040	10	32	1,250	2,500	7,500	35	72	1,250	1,250	3,750
11	31	9,920	19,840	36	11	3,520	7,040	11	32	1,250	2,500	7,500	36	72	1,250	1,250	3,750
12	29	9,280	18,560	37	11	3,520	7,040	12	32	1,250	2,500	7,500	37	72	1,250	1,250	3,750
13	27	8,640	17,280	38	11	3,520	7,040	13	32	1,250	2,500	7,500	38	72	1,250	1,250	3,750
14	26	8,320	16,640	39	10	3,200	6,400	14	44	1,250	2,500	7,500	39	72	1,250	1,250	3,750
15	24	7,680	15,360	40	10	3,200	6,400	15	44	1,250	2,500	7,500	40	72	1,250	1,250	3,750
16	23	7,360	14,720	41	10	3,200	6,400	16	44	1,250	2,500	7,500	41	72	1,250	1,250	3,750
17	22	7,040	14,080	42	10	3,200	6,400	17	44	1,250	2,500	7,500	42	72	1,250	1,250	3,750
18	21	6,720	13,440	43	9	2,880	5,760	18	44	1,250	2,500	7,500	43	72	1,250	1,250	3,750
19	20	6,400	12,800	44	9	2,880	5,760	19	44	1,250	2,500	7,500	44	72	1,250	1,250	3,750
20	19	6,080	12,160	45	9	2,880	5,760	20	44	1,250	2,500	7,500	45	88	1,250	1,250	3,750
21	18	5,760	11,520	46	9	2,880	5,760	21	44	1,250	2,500	7,500	46	88	1,250	1,250	3,750
22	17	5,440	10,880	47	9	2,880	5,760	22	44	1,250	2,500	7,500	47	88	1,250	1,250	3,750
23	17	5,440	10,880	48	8	2,560	5,120	23	56	1,250	1,250	3,750	48	88	1,250	1,250	3,750
24	16	5,120	10,240	49	8	2,560	5,120	24	56	1,250	1,250	3,750	49	88	1,250	1,250	3,750
25	16	5,120	10,240	50	8	2,560	5,120	25	56	1,250	1,250	3,750	50	88	1,250	1,250	3,750
26	15	4,800	9,600					26	56	1,250	1,250	3,750					

A4	2026/01/15	Standardization Drawing	BAO	OPERATION	DRAW	DATE	SCALE	FIT	PART NO.	 <a href="http://www.wcon.com">Http: www.wcon.com</a> WCON-Dongguan Tel: +86 769 85358920 Fax: +86 769 85358915 E-mail: sales@wcon.com WCON-Kunshan Tel: +86 512 57468408 Fax: +86 512 57468468 E-mail: salesks@wcon.com
A3	2023/02/03	ADD Flatness	XSR	x.x ±0.40	BAO	2026/01/15	UNIT	mm	2334-2XXMXXCUNX4	
A2	2014/12/30	Modify CAP	-----	x.xx ±0.25	CHECK	DATE	SIZE	A4	TITLE:	
A0	2012/07/06	NEW	-----	x.xxx ±0.15	TANG	2026/01/15	SHEET	3/3	1.27mm Female Header DUAL ROW 180°SMT LONG BODY H=3.40	
REV	DATE	MODIFICATION DESCRIPTION	CHANGE	Angle ± 3° DIM TOL	APPROVE Steven Zhao	DATE 2026/01/15	PROJ.	Customer NO.		