

HSF

NOTES: $\triangle B1$

Rated Current: 1.5AMP.(20°C, 2*2P-2*15P)
 1.0AMP.(20°C, 2*16P-2*50P)

Contact Resistance: 20mΩ Max.
 Withstand Voltage: 500V AC/DC
 Insulation Resistance: 1000MΩ Min.
 Operation Temperature: -40°C to +125°C(Gold Plating)

Contact Material: Copper Alloy
 Contact Plating: Au Over 30u" Min Ni
 Insulator Material: PA9T+G.F UL94V-0 BK

Recommended P.C.B Layout(Top Side)
 (PCB BOARD TOLERANCE ±0.05)
 (PCB Thickness: T=1.60mm)

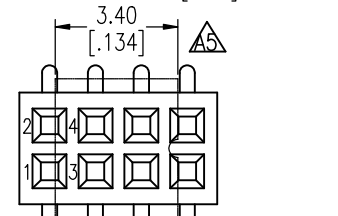
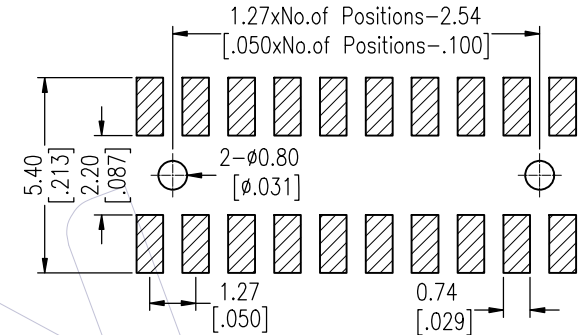
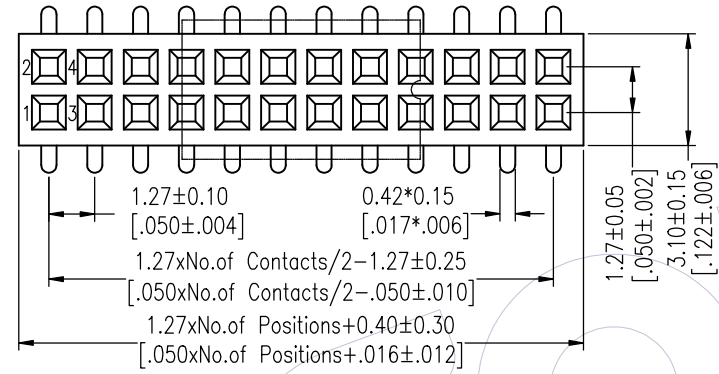

Ordering Information $\triangle B1$

2334- 2 XX M XX C U N X X

Plastic Row
 No. of Pins Per Row: 02-50
 Welding Type: M=SMT
 Contact Plating: G0=Gold Flash, G3=10u"Au, BG3=8u"PdNi+2u"Au, G4=15u"Au, BG4=13u"PdNi+2u"Au, G5=30u"Au, BG5=28u"PdNi+2u"Au

Series No. 1=Type 1, 2=Type 2
 Packing: T=Tube, P=Tube+CAP, R=Tape&Reel+CAP
 Logo N=W/O Logo
 Contact Type U=U Type
 Insulator Material C=PA9T

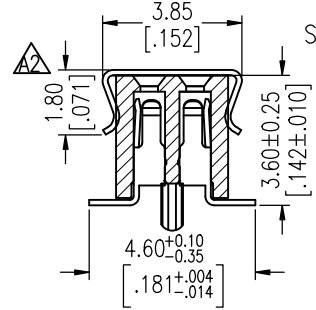
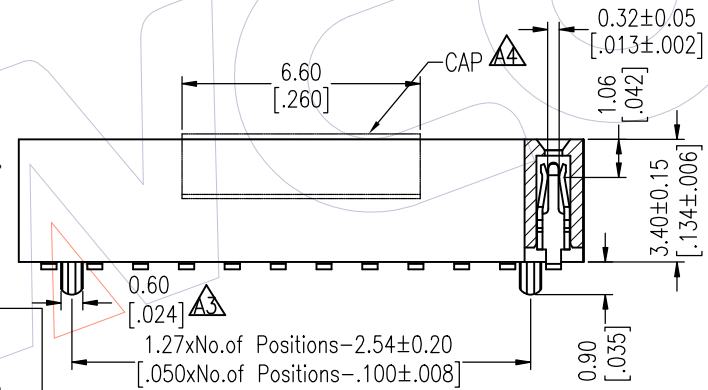

Special CAP for 2*2P, 2*3P, 2*4P

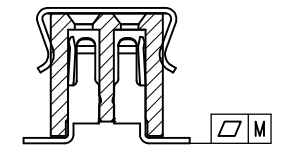

TYPE 1 W/O POST

TYPE 2 WITH POST

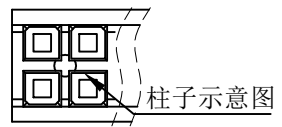
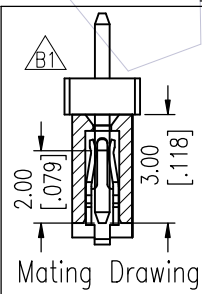

Item	Pitch	Mating	DIM.B
Standard	1.27	1310/1315/1320/3130	3.00
Alternate			

Pin(Per Row)	2-15P	16-30P	31-50P
M	0.10	0.15	0.18

TITLE	PART NO.
TYPE 1	2334-2XXMXXCUNX1
TYPE 2	2334-2XXMXXCUNX2

REV	DATE	MODIFICATION DESCRIPTION	CHANGE	OPERATION	DRAW	DATE	SCALE	FIT	PART NO.
B1	2026/01/23	Standardization Drawing	BA0	OPERATION	BAO	2026/01/23	UNIT	mm	SEE TABLE
B0	2023/02/03	Modify Flatness	-----	x.X ±0.40	CHECK	2026/01/23	SIZE	A4	TITLE: 1.27mm Female Header DUAL ROW 180°SMT H=3.40
A5	2016/06/17	Modify CAP 3.00 → 3.40	-----	x.XX ±0.25	TANG	2026/01/23	SHEET	1/3	Customer NO.
A0	2012/07/06	NEW	-----	x.XXX ±0.15	APPROVE	2026/01/23	PROJ.	∅	
				Angle ± 3°	Steven Zhao				
				DIM TOL					

WCON
 Http: www.wcon.com

WCON-Dongguan
 Tel: +86 769 85358920
 Fax: +86 769 85358915
 E-mail: sales@wcon.com

WCON-Kunshan
 Tel: +86 512 57468408
 Fax: +86 512 57468468
 E-mail: salesks@wcon.com

HSF

Packing:

Tube:

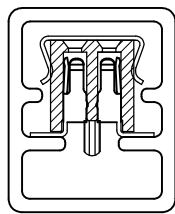

W/T CAP

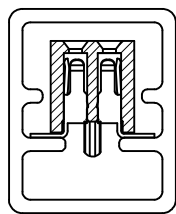

W/O CAP

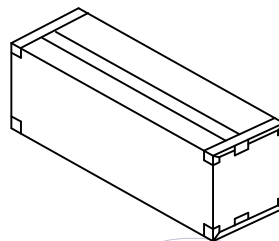
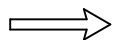

Inner Box

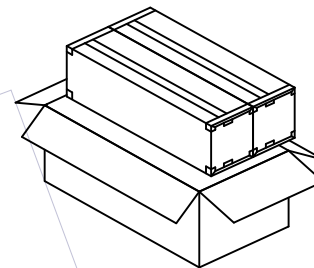
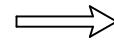

Box

Reel:

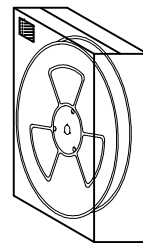
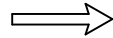
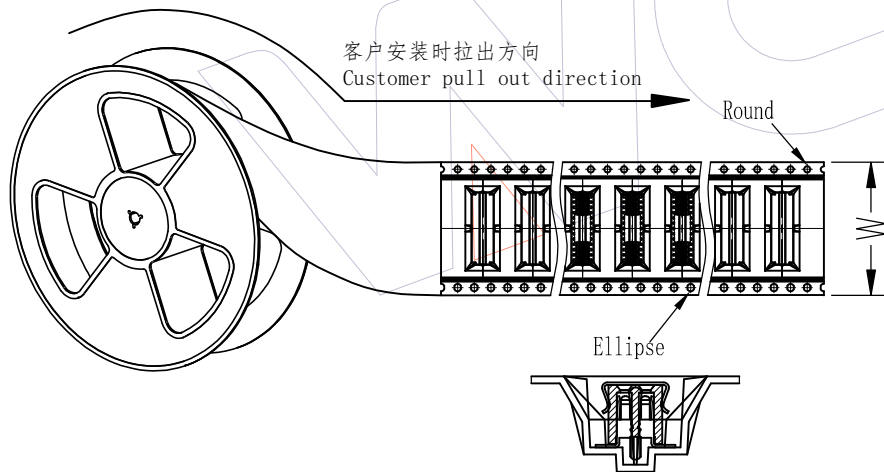

Inner Box

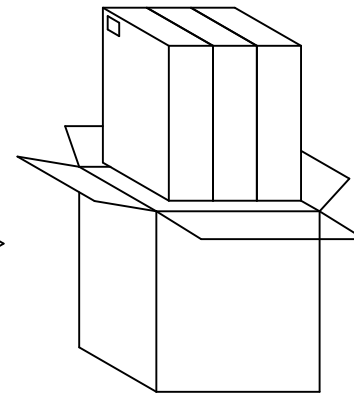
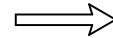

Box (Put in 3 Inner Box)

B1	2026/01/23	Standardization Drawing	BA0	OPERATION	DRAW	DATE	SCALE	FIT	PART NO.	 Http: www.wcon.com WCON-Dongguan Tel: +86 769 85358920 WCON-Kunshan Tel: +86 512 57468408 Fax: +86 769 85358915 Fax: +86 512 57468468 E-mail: sales@wcon.com E-mail: salesks@wcon.com
B0	2023/02/03	Modify Flatness	-----	x.X ±0.40	BAO	2026/01/23	UNIT	mm	SEE TABLE	
A5	2016/06/17	Modify CAP 3.00 → 3.40	-----	x.XX ±0.25	CHECK	DATE	SIZE	A4	TITLE:	
A0	2012/07/06	NEW	-----	x.XXX ±0.15	TANG	2026/01/23	SHEET	2/3	1.27mm Female Header DUAL ROW 180°SMT H=3.40	
REV	DATE	MODIFICATION DESCRIPTION	CHANGE	Angle ± 3° DIM TOL	APPROVE Steven Zhao	DATE 2026/01/23	PROJ.	Customer NO.		

HSF

⚠ Packaging Quantity Refers To The Following Table

PINS /Row	Q' ty/Tube	Q' ty/Inner Box	Q' ty/Box	PINS /Row	Q' ty/Tube	Q' ty/Inner Box	Q' ty/Box	PINS /Row	W	Q' ty/Reel	Q' ty/Inner Box	Q' ty/Box	PINS /Row	W	Q' ty/Reel	Q' ty/Inner Box	Q' ty/Box
2	800/Tray	/	38,400	27	16	5,120	10,240	2	12	1,050	6,300	18,900	26	56	1,050	1,050	3,150
3	137	43,840	87,680	28	16	5,120	10,240	3	16	1,050	4,200	12,600	27	56	1,050	1,050	3,150
4	105	33,600	67,200	29	15	4,800	9,600	4	16	1,050	4,200	12,600	28	56	1,050	1,050	3,150
5	86	27,520	55,040	30	14	4,480	8,960	5	24	1,600	4,800	14,400	29	56	1,050	1,050	3,150
6	72	23,040	46,080	31	14	4,480	8,960	6	24	1,050	3,150	9,450	30	56	1,050	1,050	3,150
7	62	19,840	39,680	32	14	4,480	8,960	7	24	1,050	3,150	9,450	31	56	1,050	1,050	3,150
8	54	17,280	34,560	33	13	4,160	8,320	8	24	1,600	4,800	14,400	32	56	1,050	1,050	3,150
9	49	15,680	31,360	34	13	4,160	8,320	9	24	1,050	3,150	9,450	33	56	1,050	1,050	3,150
10	44	14,080	28,160	35	12	3,840	7,680	10	24	1,600	4,800	14,400	34	56	1,050	1,050	3,150
11	40	12,800	25,600	36	12	3,840	7,680	11	24	1,050	3,150	9,450	35	56	1,050	1,050	3,150
12	37	11,840	23,680	37	12	3,840	7,680	12	24	1,050	3,150	9,450	36	72	1,050	1,050	3,150
13	34	10,880	21,760	38	11	3,520	7,040	13	32	1,050	2,100	6,300	37	72	1,050	1,050	3,150
14	31	9,920	19,840	39	11	3,520	7,040	14	44	1,050	2,100	6,300	38	72	1,050	1,050	3,150
15	29	9,280	18,560	40	11	3,520	7,040	15	44	1,050	2,100	6,300	39	72	1,050	1,050	3,150
16	27	8,640	17,280	41	11	3,520	7,040	16	44	1,050	2,100	6,300	40	72	1,050	1,050	3,150
17	26	8,320	16,640	42	10	3,200	6,400	17	44	1,050	2,100	6,300	41	72	1,050	1,050	3,150
18	24	7,680	15,360	43	10	3,200	6,400	18	44	1,050	2,100	6,300	42	72	1,050	1,050	3,150
19	23	7,360	14,720	44	10	3,200	6,400	19	44	1,050	2,100	6,300	43	72	1,050	1,050	3,150
20	22	7,040	14,080	45	10	3,200	6,400	20	44	1,050	2,100	6,300	44	72	1,050	1,050	3,150
21	21	6,720	13,440	46	9	2,880	5,760	21	44	1,050	2,100	6,300	45	72	1,050	1,050	3,150
22	20	6,400	12,800	47	9	2,880	5,760	22	44	1,050	2,100	6,300	46	72	1,050	1,050	3,150
23	19	6,080	12,160	48	9	2,880	5,760	23	44	1,050	2,100	6,300	47	72	1,050	1,050	3,150
24	18	5,760	11,520	49	9	2,880	5,760	24	44	1,050	2,100	6,300	48	88	1,050	1,050	3,150
25	18	5,760	11,520	50	9	2,880	5,760	25	44	1,050	2,100	6,300	49	88	1,050	1,050	3,150
26	17	5,440	10,880										50	88	1,050	1,050	3,150

B1	2026/01/23	Standardization Drawing	BA0	OPERATION	DRAW	DATE	SCALE	FIT	PART NO.	 Http: www.wcon.com WCON-Dongguan Tel: +86 769 85358920 WCON-Kunshan Tel: +86 512 57468408 Fax: +86 769 85358915 Fax: +86 512 57468468 E-mail: sales@wcon.com E-mail: sales@wcon.com
B0	2023/02/03	Modify Flatness	-----	x.X ±0.40	BA0	2026/01/23	UNIT	mm	SEE TABLE	
A5	2016/06/17	Modify CAP 3.00 → 3.40	-----	x.XX ±0.25	CHECK	DATE	SIZE	A4	TITLE:	
A0	2012/07/06	NEW	-----	x.XXX ±0.15	TANG	2026/01/23	SHEET	3/3	1.27mm Female Header DUAL ROW 180°SMT H=3.40	
REV	DATE	MODIFICATION DESCRIPTION	CHANGE	Angle ± 3° DIM TOL	APPROVE Steven Zhao	DATE 2026/01/23	PROJ.	Customer NO.		