

HSF

Packing:

Tube:

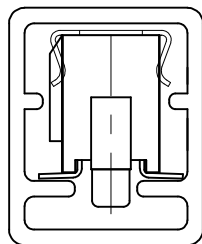

W/T CAP

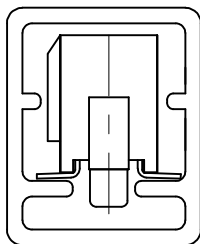

W/O CAP

Tube

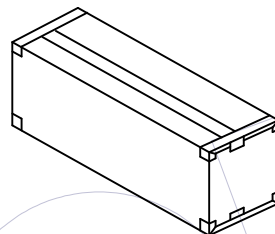

Inner Box

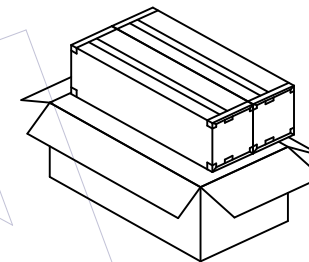

Box

Reel:

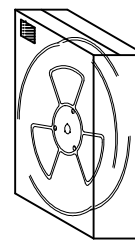
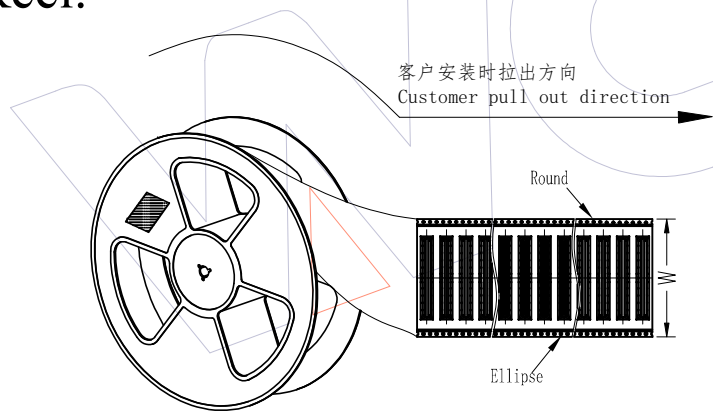

Inner Box

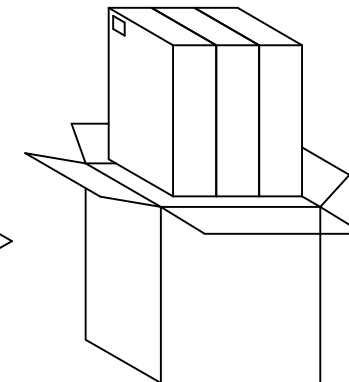

Box (Put in 3 Inner Box)

B0	2026/02/03	Standardization Drawing	CP	OPERATION	DRAW	DATE	SCALE	FIT	PART NO.
A5	2023/02/03	Modify Flatness	XSR	x.xx ±0.40	CP	2026/02/03	UNIT	mm	2344-2XXMXXCUNXX
A4	2016/06/17	Modify CAP 3.00 → 3.40	Wang	x.xx ±0.25	CHECK	DATE	SIZE	A4	TITLE:
A1	2012/09/05	Add C0.3	JYHuang	x.xxx ±0.15	TANG	2026/02/03	SHEET	2/3	1.27mm Female Header DUAL SMT
REV	DATE	MODIFICATION DESCRIPTION	CHANGE	Angle ± 3°	APPROVE	DATE	PROJ.	Customer NO.	
				DIM TOL	Steven Zhao	2026/02/03			

WCON

Http: www.wcon.com

WCON-Dongguan
Tel: +86 769 85358920
Fax: +86 769 85358915
E-mail: sales@wcon.com

WCON-Kunshan
Tel: +86 512 57468408
Fax: +86 512 57468468
E-mail: salesk@wcon.com

HSF

Packaging Quantity Refers To The Following Table

PINS /Row	Q' ty/Tube	Q' ty/Inner Box	Q' ty/Box
2	400/Tray		19,200
3	300/Tray		14,400
4	70	22,400	44,800
5	61	19,520	39,040
6	54	17,280	34,560
7	48	15,360	30,720
8	43	13,760	27,520
9	39	12,480	24,960
10	36	11,520	23,040
11	33	10,560	21,120
12	31	9,920	19,840
13	29	9,280	18,560
14	27	8,640	17,280
15	26	8,320	16,640
16	24	7,680	15,360
17	23	7,360	14,720
18	22	7,040	14,080
19	21	6,720	13,440
20	20	6,400	12,800
21	19	6,080	12,160
22	18	5,760	11,520
23	17	5,440	10,880
24	17	5,440	10,880
25	16	5,120	10,240
26	16	5,120	10,240

PINS /Row	Q' ty/Tube	Q' ty/Inner Box	Q' ty/Box
27	15	4,800	9,600
28	15	4,800	9,600
29	14	4,480	8,960
30	14	4,480	8,960
31	13	4,160	8,320
32	13	4,160	8,320
33	12	3,840	7,680
34	12	3,840	7,680
35	12	3,840	7,680
36	11	3,520	7,040
37	11	3,520	7,040
38	11	3,520	7,040
39	11	3,520	7,040
40	10	3,200	6,400
41	10	3,200	6,400
42	10	3,200	6,400
43	10	3,200	6,400
44	9	2,880	5,760
45	9	2,880	5,760
46	9	2,880	5,760
47	9	2,880	5,760
48	9	2,880	5,760
49	8	2,560	5,120
50	8	2,560	5,120

PINS /Row	W	Q' ty/Reel	Q' ty/Inner Box	Q' ty/Box
2	16	900	3,600	10,800
3	24	900	2,700	8,100
4	24	900	2,700	8,100
5	24	900	2,700	8,100
6	24	900	2,700	8,100
7	24	900	2,700	8,100
8	24	900	2,700	8,100
9	32	900	1,800	5,400
10	32	900	1,800	5,400
11	32	850	1,700	5,100
12	32	900	1,800	5,400
13	32	900	1,800	5,400
14	32	900	1,800	5,400
15	44	900	1,800	5,400
16	44	900	1,800	5,400
17	44	900	1,800	5,400
18	44	900	1,800	5,400
19	44	900	1,800	5,400
20	44	900	1,800	5,400
21	44	900	1,800	5,400
22	56	900	900	2,700
23	56	900	900	2,700
24	56	900	900	2,700
25	56	900	900	2,700
26	56	900	900	2,700

PINS /Row	W	Q' ty/Reel	Q' ty/Inner Box	Q' ty/Box
27	56	900	900	2,700
28	56	900	900	2,700
29	56	900	900	2,700
30	56	900	900	2,700
31	56	900	900	2,700
32	56	900	900	2,700
33	72	900	900	2,700
34	72	900	900	2,700
35	72	900	900	2,700
36	72	900	900	2,700
37	72	900	900	2,700
38	72	900	900	2,700
39	72	900	900	2,700
40	72	900	900	2,700
41	72	900	900	2,700
42	72	900	900	2,700
43	72	900	900	2,700
44	72	900	900	2,700
45	88	900	900	2,700
46	88	900	900	2,700
47	88	900	900	2,700
48	88	900	900	2,700
49	88	900	900	2,700
50	88	900	900	2,700

B0	2026/02/03	Standardization Drawing	CP	OPERATION	DRAW CP	DATE	SCALE	FIT	PART NO.
A5	2023/02/03	Modify Flatness	XSR	x.X ±0.40	CP	2026/02/03	UNIT	mm	2344-2XXMXXCUNXX
A4	2016/06/17	Modify CAP 3.00 → 3.40	Wang	x.XX ±0.25	CHECK TANG	DATE	SIZE	A4	TITLE:
A1	2012/09/05	Add C0.3	JYHuang	x.XXX ±0.15	APPROVE Steven Zhao	2026/02/03	SHEET	3/3	1.27mm Female Header DUAL SMT
REV	DATE	MODIFICATION DESCRIPTION	CHANGE	Angle ± 3°	DIM TOL	DATE	PROJ.	Customer NO.	W/T Diff. Post&Bump Or W/T Diff. Post



WCON-Dongguan Tel: +86 769 85358920 Fax: +86 769 85358915 E-mail: sales@wcon.com	WCON-Kunshan Tel: +86 512 57468408 Fax: +86 512 57468468 E-mail: salesks@wcon.com
---	--