

HSF

NOTES:

Current Rating: 1.5AMP.(20°C, 2*2P-2*15P)
 1.0AMP.(20°C, 2*16P-2*50P)

Contact Resistance: 20mΩ Max
 Withstand Voltage: 500V AC

Insulation Resistance: 1000MΩ Min
 Operation Temperature: -40°C to +125°C (Gold Plating)
 -40°C to +105°C (Tin Plating)

Contact Material: Copper Alloy
 Contact plating: Au Or Sn Over 30u" Min Ni
 Insulator Material: PA9T+G.F UL94V-0

Ordering Information

2344- 2 XX M XX C U N X X

Plastic Row
 No. of Pins Per Row: 02-50
 Welding Type M=SMT
 Contact Plating
 G0=Gold Flash
 G3=10u"Au, BG3=8u"PdNi+2u"Au
 G4=15u"Au, BG4=13u"PdNi+2u"Au
 G5=30u"Au, BG5=28u"PdNi+2u"Au
 S0=Gold Flash/Tin
 S3=10u"Au/Sn, P3=8u"PdNi+2u"Au/Sn
 S4=15u"Au/Sn, P4=13u"PdNi+2u"Au/Sn
 S5=30u"Au/Sn, P5=28u"PdNi+2u"Au/Sn
 SN=Bright Tin

Series No.
 1=TYPE 1
 2=TYPE 2

Packing:
 T=Tube
 P=Tube+CAP
 R=Tape&Reel+CAP

Logo
 N=W/O Logo

Contact Type
 U=U Type

Insulator Material
 C=PA9T

Item	Pitch	Mating	DIM.B
Standard	1.27	1310/1315/1320/3131/3133/3100	3.00
Alternate			

REV	DATE	MODIFICATION DESCRIPTION	CHANGE	DIM	TOL	OPERATION	DRAW	DATE	SCALE	FIT	PART NO.
B0	2026/02/02	Standardization Drawing	CP			OPERATION	DRAW	2026/02/02	SCALE	FIT	PART NO.
A5	2023/02/03	Modify Flatness	XSR	x.x	±0.40	OPERATION	CP	2026/02/02	UNIT	mm	SEE TABLE
A4	2016/06/17	Modify CAP 3.00 → 3.40	Wang	x.xx	±0.25	CHECK	TANG	2026/02/02	SIZE	A4	TITLE:
A0	2012/07/09	NEW	Wang	x.xxx	±0.15	APPROVE	STEVEN ZHAO	2026/02/02	SHEET	1/3	1.27mm Female Header DUAL ROW
				Angle	± 3'				PROJ.		180°SMT H=4.30
											Customer NO.

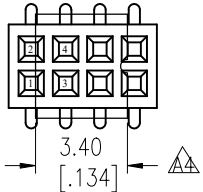

Special CAP for 2*2P, 2*3P, 2*4P

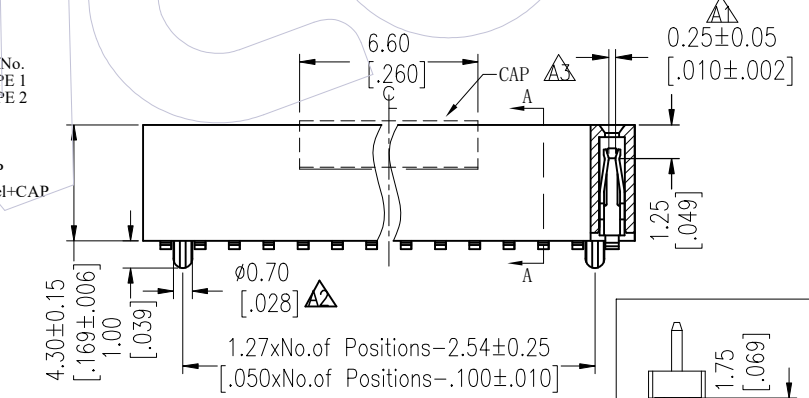
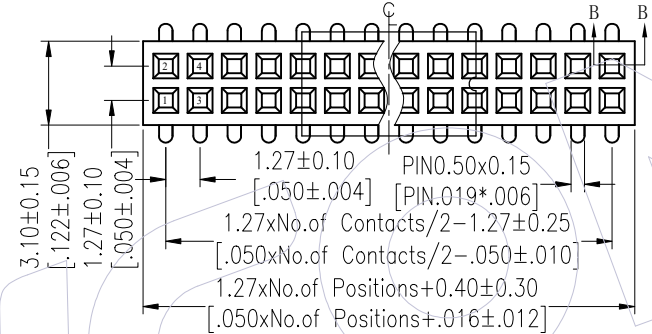

SECTION B-B

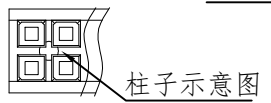

Recommended P.C.B Layout (Top Side)
 (PCB BOARD TOLERANCE ±0.05)
 (PCB Thickness: T=1.60mm)

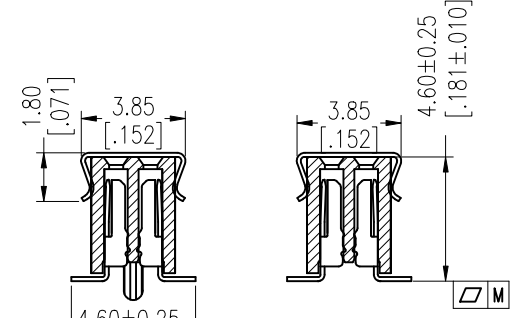
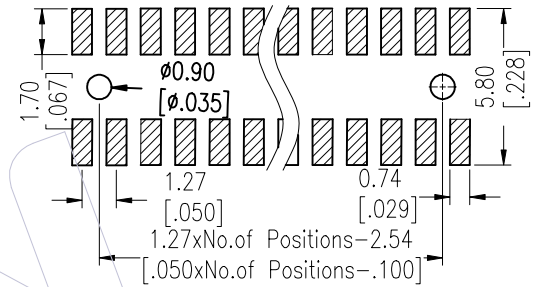

TYPE 1 W/O POST
 TYPE 2 WITH POST
 SECTION A-A

Pin (Per Row)	2-15P	16-30P	31-50P
M	0.10	0.15	0.18

TITLE	PART NO.
TYPE 1	2344-2XXMXXCUNX1
TYPE 2	2344-2XXMXXCUNX2

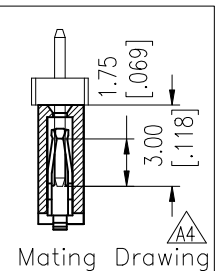

Mating Drawing

WCON
 Http: www.wcon.com

WCON-Dongguan
 Tel: +86 769 85358920
 Fax: +86 769 85358915
 E-mail: sales@wcon.com

WCON-Kunshan
 Tel: +86 512 57468408
 Fax: +86 512 57468468
 E-mail: sales@wcon.com

HSF

Packing:

Tube:

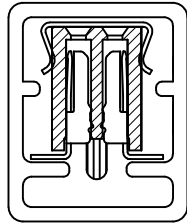

W/T CAP

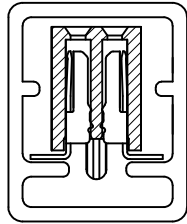

W/O CAP

Tube

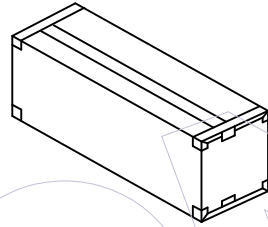

Inner Box

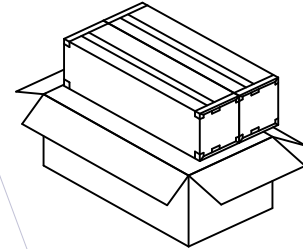

Box

Reel:

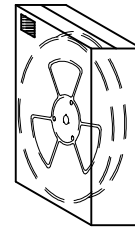
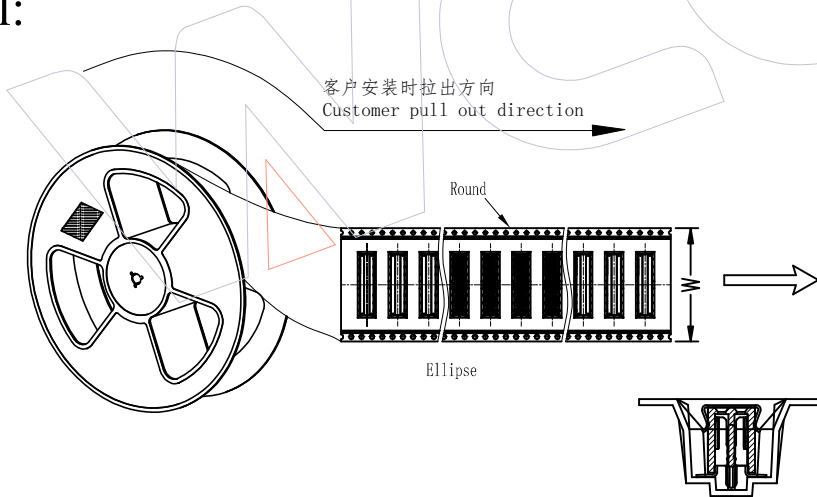

Inner Box

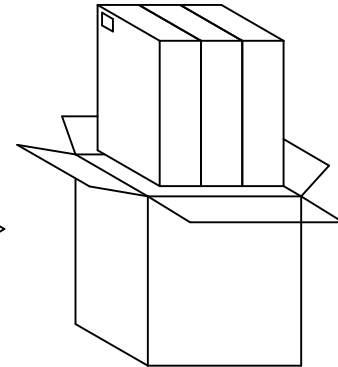

Box (Put in 3 Inner Box)

B0	2026/02/02	Standardization Drawing	CP	OPERATION	DRAW	DATE	SCALE	FIT	PART NO.
A5	2023/02/03	Modify Flatness	XSR	x.X ±0.40	CP	2026/02/02	UNIT	mm	SEE TABLE
A4	2016/06/17	Modify CAP 3.00 → 3.40	Wang	x.XX ±0.25	CHECK	DATE	SIZE	A4	TITLE:
A0	2012/07/09	NEW	Wang	x.XXX ±0.15	TANG	2026/02/02	SHEET	2/3	1.27mm Female Header DUAL ROW
REV	DATE	MODIFICATION DESCRIPTION	CHANGE	Angle ± 3'	APPROVE	DATE	PROJ.	Customer NO.	
				DIM TOL	Steven Zhao	2026/02/02			



Http: www.wcon.com

WCON-Dongguan
Tel: +86 769 85358920
Fax: +86 769 85358915
E-mail: sales@wcon.com

WCON-Kunshan
Tel: +86 512 57468408
Fax: +86 512 57468468
E-mail: salesks@wcon.com

HSF

Packaging Quantity Refers To The Following Table

PINS /Row	Q' ty/Tube	Q' ty/Inner Box	Q' ty/Box
2	800/Tray		38,400
3	137	43,840	87,680
4	105	33,600	67,200
5	86	27,520	55,040
6	72	23,040	46,080
7	62	19,840	39,680
8	54	17,280	34,560
9	49	15,680	31,360
10	44	14,080	28,160
11	40	12,800	25,600
12	37	11,840	23,680
13	34	10,880	21,760
14	31	9,920	19,840
15	29	9,280	18,560
16	27	8,640	17,280
17	26	8,320	16,640
18	24	7,680	15,360
19	23	7,360	14,720
20	22	7,040	14,080
21	21	6,720	13,440
22	20	6,400	12,800
23	19	6,080	12,160
24	18	5,760	11,520
25	18	5,760	11,520
26	17	5,440	10,880

PINS /Row	Q' ty/Tube	Q' ty/Inner Box	Q' ty/Box
27	16	5,120	10,240
28	16	5,120	10,240
29	15	4,800	9,600
30	14	4,480	8,960
31	14	4,480	8,960
32	14	4,480	8,960
33	13	4,160	8,320
34	13	4,160	8,320
35	12	3,840	7,680
36	12	3,840	7,680
37	12	3,840	7,680
38	11	3,520	7,040
39	11	3,520	7,040
40	11	3,520	7,040
41	11	3,520	7,040
42	10	3,200	6,400
43	10	3,200	6,400
44	10	3,200	6,400
45	10	3,200	6,400
46	9	2,880	5,760
47	9	2,880	5,760
48	9	2,880	5,760
49	9	2,880	5,760
50	9	2,880	5,760

PINS /Row	W	Q' ty/Reel	Q' ty/Inner Box	Q' ty/Box
2	16	900	3,600	10,800
3	16	900	3,600	10,800
4	24	900	2,700	8,100
5	24	900	2,700	8,100
6	24	900	2,700	8,100
7	24	900	2,700	8,100
8	24	900	2,700	8,100
9	24	900	2,700	8,100
10	24	900	2,700	8,100
11	32	900	1,800	5,400
12	32	900	1,800	5,400
13	32	900	1,800	5,400
14	32	900	1,800	5,400
15	44	900	1,800	5,400
16	44	900	1,800	5,400
17	44	900	1,800	5,400
18	44	900	1,800	5,400
19	44	900	1,800	5,400
20	44	900	1,800	5,400
21	44	900	1,800	5,400
22	56	900	1,800	5,400
23	56	900	1,800	5,400
24	56	900	1,800	5,400
25	56	900	900	2,700
26	56	900	900	2,700

PINS /Row	W	Q' ty/Reel	Q' ty/Inner Box	Q' ty/Box
27	56	900	900	2,700
28	56	900	900	2,700
29	56	900	900	2,700
30	56	900	900	2,700
31	56	900	900	2,700
32	56	900	900	2,700
33	56	900	900	2,700
34	56	900	900	2,700
35	72	900	900	2,700
36	72	900	900	2,700
37	72	900	900	2,700
38	72	900	900	2,700
39	72	900	900	2,700
40	72	900	900	2,700
41	72	900	900	2,700
42	72	900	900	2,700
43	72	900	900	2,700
44	72	900	900	2,700
45	72	900	900	2,700
46	72	900	900	2,700
47	88	900	900	2,700
48	88	900	900	2,700
49	88	900	900	2,700
50	88	900	900	2,700

B0	2026/02/02	Standardization Drawing	CP	OPERATION	DRAW	DATE	SCALE	FIT	PART NO.
A5	2023/02/03	Modify Flatness	XSR	x.X ±0.40	CP	2026/02/02	UNIT	mm	SEE TABLE
A4	2016/06/17	Modify CAP 3.00 → 3.40	Wang	x.XX ±0.25	CHECK	DATE	SIZE	A4	TITLE:
A0	2012/07/09	NEW	Wang	x.XXX ±0.15	TANG	2026/02/02	SHEET	3/3	1.27mm Female Header DUAL ROW
REV	DATE	MODIFICATION DESCRIPTION	CHANGE	Angle ± 3'	APPROVE	DATE	PROJ.	Customer NO.	
				DIM TOL	Steven Zhao	2026/02/02			

WCON

Http: www.wcon.com

WCON-Dongguan
Tel: +86 769 85358920
Fax: +86 769 85358915
E-mail: sales@wcon.com

WCON-Kunshan
Tel: +86 512 57468408
Fax: +86 512 57468468
E-mail: sales@wcon.com