

HSF

NOTES:

Current Rating: 1.5AMP.(20°C, 2*2P-2*15P)
 1.0AMP.(20°C, 2*16P-2*50P)

Contact Resistance: 20mΩ Max
 Withstand Voltage: 500V AC/DC
 Insulation Resistance: 1000MΩ Min
 Operation Temperature: -40°C to +125°C(Gold Plating)
 -40°C to +105°C(Tin Plating)

Contact Material: Copper Alloy
 Contact plating: Au Or Sn Over 30u" Min Ni
 Insulator Material: PA9T+G.F UL94V-0

Ordering Information

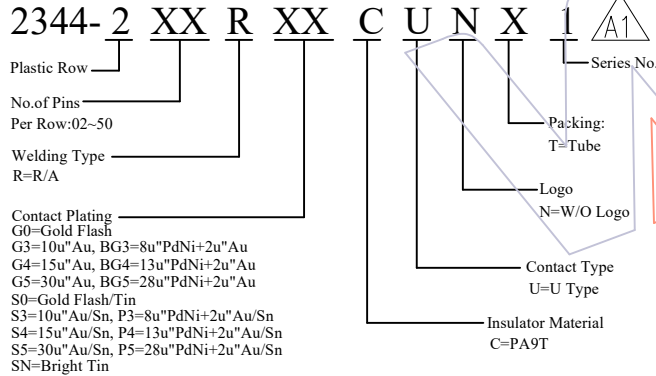

Contact Plating
 G0=Gold Flash
 G3=10u"Au, BG3=8u"PdNi+2u"Au
 G4=15u"Au, BG4=13u"PdNi+2u"Au
 G5=30u"Au, BG5=28u"PdNi+2u"Au
 S0=Gold Flash/Tin
 S3=10u"Au/Sn, P3=8u"PdNi+2u"Au/Sn
 S4=15u"Au/Sn, P4=13u"PdNi+2u"Au/Sn
 S5=30u"Au/Sn, P5=28u"PdNi+2u"Au/Sn
 SN=Bright Tin

Recommended P.C.B Layout(Top Side)
 (PCB BOARD TOLERANCE±0.05)
 (PCB Thickness:T=1.60m)

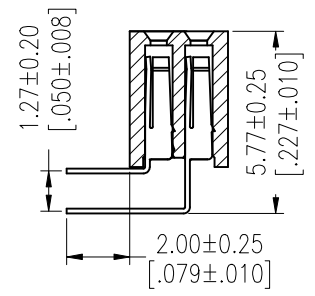
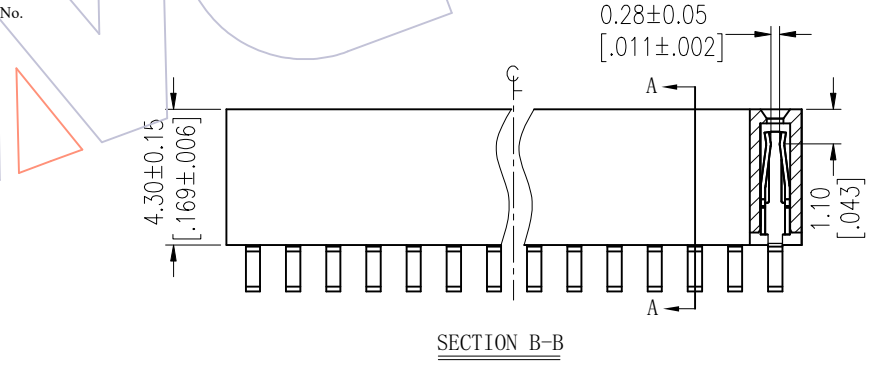
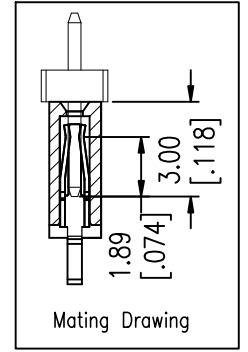
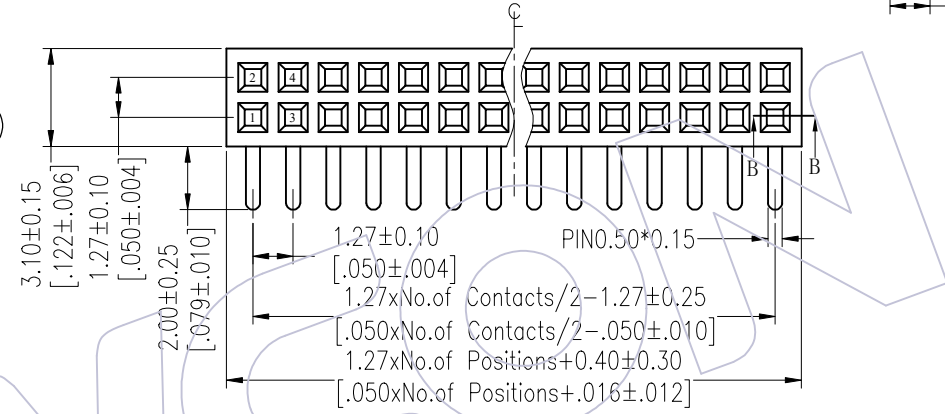
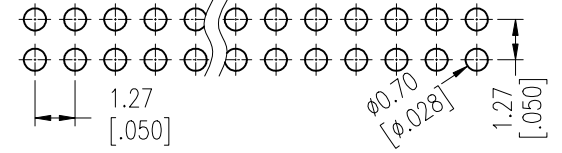

Item	Pitch	Mating	DIM.B
Standard	1.27	1310/1315/1320	3.00
Alternate			

REV	DATE	MODIFICATION DESCRIPTION	CHANGE	OPERATION	DRAW CP	DATE	SCALE	FIT	PART NO.
A1	2026/02/02	Standardization Drawing	CP	x.X ±0.40	CHECK TANG	2026/02/02	UNIT mm	A4	2344-2XXRXXCUNT1
AO	2012/07/11	NEW	JYHuang	x.XX ±0.25	APPROVE Steven Zhao	2026/02/02	SIZE A4	1/2	FH1. 27mm DUAL ROW 90° DIP H=4.30
				x.XXX ±0.15			SHEET 1/2		
				Angle ± 3'					Customer NO.
				DIM TOL					

WCON
 Http: www.wcon.com

WCON-Dongguan
 Tel: +86 769 85358920
 Fax: +86 769 85358915
 E-mail: sales@wcon.com

WCON-Kunshan
 Tel: +86 512 57468408
 Fax: +86 512 57468468
 E-mail: salesks@wcon.com

HSF

Packing:

Packaging Quantity Refers To The Following Table

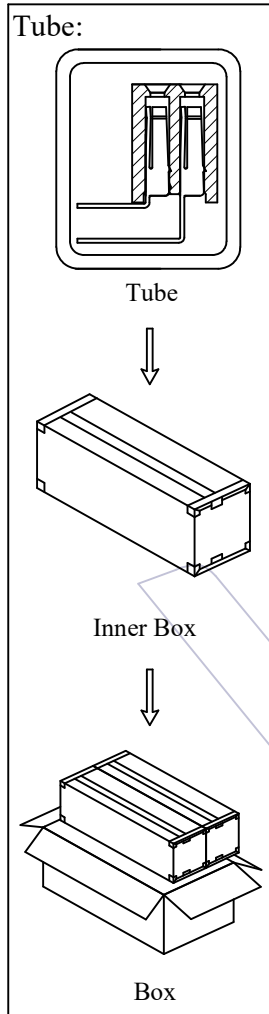

PINS /Row	Q' ty/Tube	Q' ty/Inner Box	Q' ty/Box
2	800/Tray		38,400
3	137	41,100	82,200
4	105	31,500	63,000
5	85	25,500	51,000
6	72	21,600	43,200
7	62	18,600	37,200
8	54	16,200	32,400
9	49	14,700	29,400
10	44	13,200	26,400
11	40	12,000	24,000
12	37	11,100	22,200
13	34	10,200	20,400
14	31	9,300	18,600
15	29	8,700	17,400
16	27	8,100	16,200
17	26	7,800	15,600
18	24	7,200	14,400
19	23	6,900	13,800
20	22	6,600	13,200
21	21	6,300	12,600
22	20	6,000	12,000
23	19	5,700	11,400
24	18	5,400	10,800
25	18	5,400	10,800
26	17	5,100	10,200

PINS /Row	Q' ty/Tube	Q' ty/Inner Box	Q' ty/Box
27	16	4,800	9,600
28	16	4,800	9,600
29	15	4,500	9,000
30	15	4,500	9,000
31	14	4,200	8,400
32	14	4,200	8,400
33	13	3,900	7,800
34	13	3,900	7,800
35	12	3,600	7,200
36	12	3,600	7,200
37	12	3,600	7,200
38	11	3,300	6,600
39	11	3,300	6,600
40	11	3,300	6,600
41	10	3,000	6,000
42	10	3,000	6,000
43	10	3,000	6,000
44	10	3,000	6,000
45	10	3,000	6,000
46	9	2,700	5,400
47	9	2,700	5,400
48	9	2,700	5,400
49	9	2,700	5,400
50	9	2,700	5,400

		OPERATION		DRAW CP		DATE		SCALE		FIT		PART NO.	
REV	DATE	MODIFICATION DESCRIPTION		CHANGE	DIM	TOL	DATE	UNIT	mm	TITLE:		Customer NO.	
A1	2026/02/02	Standardization Drawing		CP	x.X	±0.40	2026/02/02			FH1. 27mm DUAL ROW 90° DIP H=4.30		2344-2XXRXXCUNT1	
AO	2012/07/11	NEW		JYHuang	x.XX	±0.25	2026/02/02	SIZE	A4				
					x.XXX	±0.15		SHEET	2/2				
					Angle	± 3'		PROJ.	⊕				
							2026/02/02						



Http: www.wcon.com

<p>WCON-Dongguan Tel: +86 769 85358920 Fax: +86 769 85358915 E-mail: sales@wcon.com</p>	<p>WCON-Kunshan Tel: +86 512 57468408 Fax: +86 512 57468468 E-mail: salesks@wcon.com</p>
---	--